

Operating instructions and spare parts list

DOK-013-GB.doc Rev. 1

Spray gun

Type DUO-H

Order-No.: 3210-090-.... nozzle system "slot air"

Order-No.: 3200-090-.... nozzle system „horn air“

- keep for further use-

CE

100
100 JAHRE
KRAUTZBERGER

Krautzberger 

EG-Konformitätserklärung

CE Declaration of Conformity, Déclaration de conformité européenne, Declaración de conformidad CE
gemäß Anhang II A der EG – Maschinenrichtlinie 98/37/EG

in acc. with Annex II A of the EC Machine Directive 98/37/EC, Selon la directive européenne 98/37/CEE, annexe II A, relative aux machines, según Anexo II A de la Directiva sobre maquinaria CE 98/37/EG

Krautzberger 
Krautzberger GmbH
Stockbornstraße 13
65343 Eltville am Rhein

Hiermit erklären wir, dass folgendes Produkt

We hereby declare that the following product, garantissons que la version livrée des machines mentionnées ci-dessous, Por la presente declaramos que el siguiente producto

Bezeichnung **Spray gun ■ DUO H**

Designation, Désignation, Denominación

Geräte-Nr. ■ **3200**

Unit no., N° de l'appareil, Núm. aparatos ■ **3210**

Funktion **Beschichtung von Oberflächen**

Function, Fonction, Funcionamiento Coating of surfaces

In der gelieferten Ausführung folgenden Bestimmungen entspricht:

complies with the following provisions in its delivered version:, satisfait aux exigences suivantes :, de la versión suministrada responde a las siguientes disposiciones:

EG – Maschinenrichtlinie 98/37/EG,

EC Machine Directive 98/37/EC, Directive européenne 98/37/CEE relative aux machines, Directiva sobre maquinaria CE 98/37/EG

Folgende harmonisierte EU-Normen wurden angewendet:

The following harmonised EU standards were applied:, Les normes d'harmonisation européennes suivantes ont été appliquées :, Se han aplicado las siguientes normas UE armonizadas:

DIN EN 292 Teil 1 und 2 DIN EN 1050

DIN EN 1953

Folgende nationale Normen wurden angewendet:

The following national standards were applied:, Les normes nationales suivantes ont été appliquées :, Se han aplicado las siguientes normas nacionales:

Datum / Unterschrift 14.11.00, i.A.

Date / Signature, Date/ signature, Fecha / Firma



Angaben zum Unterzeichner **Leiter Konstruktion** **M.Stoffels**

Details of signatory, Fonction, Mención del firmante Head of Design, Directeur de la construction, Director de diseño

CONTEND

USE FOR INTENDED PURPOSE	3
MODE OF OPERATION	3
GENERAL SAFETY NOTES	3
SAFETY NOTES WHEN USING HAZARDOUS SUBSTANCES	4
CONNECTIONS	5
START-UP	5
OPERATIONAL INTERRUPTIONS, CLEANING	6
MAINTENANCE	6
SPARE PARTS DRAWING	8
ACCESSORIES	10

Use for intended purpose

The DUO-H spray gun is designed to allow coating of surfaces with liquid to low-viscosity coating materials. Typical coating substances are, for example, lacquers, paints, adhesives, glazes, enamel, release agents etc.

Mode of operation

The coating material is fed to the automatic spray gun under pressure. This pressure is typically generated by piston-pumps.

The spraying process is activated when the trigger is pressed and stopped when the trigger is released.

The coating material is atomised by using a special "airless" material nozzle and compressed air (*airmix-process*).

The scope and shape of the jet and the spray volume of the coating material can be adjusted by:

- choosing between various nozzles and aircaps

- changing the atomiser air pressure
- changing the coating material pressure
- adjusting the needle stroke on the regulator of the spray gun
- adjusting the jet regulator of the spray gun

General safety notes

PERSONNEL MAY ONLY WORK WITH SPRAY GUNS IF THEY HAVE BEEN TRAINED AND INSTRUCTED IN THE FOLLOWING POINTS:

- POTENTIAL HAZARDS WHEN USING SPRAY GUNS
- SAFETY REGULATIONS
- CONDUCT IN THE EVENT OF ACCIDENT AND MALFUNCTION
- CONTENTS OF THE OPERATING INSTRUCTIONS

 SPRAY GUNS MAY ONLY BE OPERATED IN LINE WITH THE OPERATING PARAMETERS (PRESSURES ETC.) SPECIFIED UNDER "TECHNICAL DATA"!

 THE OPERATOR MUST CHECK THE COMPATIBILITY OF THE GUN MATERIALS WITH THE COATING SUBSTANCE TO BE USED. TO ENSURE COMPATIBILITY, REFER TO THE SAFETY DATA SHEET SUPPLIED BY THE MANUFACTURER OF THE COATING SUBSTANCE!

 ALL WORK CONNECTED WITH INSTALLATION AND MAINTENANCE MUST BE PERFORMED ON A PRESSURELESS GUN BY SUITABLY QUALIFIED PERSONNEL. ALWAYS USE ORIGINAL PARTS WHEN REPLACING WORN OR DAMAGED PARTS!

 EACH TIME BEFORE YOU START WORKING, CHECK THE MATERIAL AND COMPRESSED AIR CONNECTIONS FOR FIRM SEAT AND DAMAGE! LOOSE, PRESSURISED HOSES MAY CAUSE ACCIDENTS DUE TO WHIPLASH-LIKE MOVEMENT AND THE DISCHARGE OF FLUIDS!

 NEVER POINT COMPRESSED AIR AT PEOPLE OR ANIMALS!

 HIGHLY ABRASIVE, CHEMICALLY AGGRESSIVE, EXTREMELY HOT OR EXTREMELY COLD MATERIALS MAY ONLY BE USED IN CONSULTATION WITH KRAUTZBERGER GMBH!

 DEPENDING ON THE NOZZLE, WORKING WITH SPRAY GUNS CAN CREATE NOISE LEVELS THAT MAY DAMAGE HEARING! ALWAYS WEAR EAR MUFFS WHEN WORKING!

 MIXING OF DIFFERENT COATING SUBSTANCES CAN CREATE SUBSTANCES WITH INCREASED HAZARD POTENTIAL. ADHERE TO THE INSTRUCTIONS OF THE MANUFACTURER!

 DURING LONG-TERM USE, THE RECOIL FORCES CREATED WHEN THE SPRAYING PROCESS IS ACTIVATED CAN DAMAGE THE CENTRAL NERVOUS SYSTEM!

 VIBRATIONS CAUSED BY PULSATION-TYPE PRESSURE GENERATING UNITS (PUMPS, COMPRESSORS) CAN BE TRANSMITTED TO THE SPRAY GUN VIA HOSE LINES. DURING LONG-TERM USE, VIBRATIONS CAN CAUSE DAMAGE TO THE NERVOUS SYSTEM AND VASCULAR DISORDERS. VIBRATION LEVELS CAN BE REDUCED BY USING PULSATION-CUSHIONING DEVICES (PRESSURE EQUALISATION TANK ETC.)

Safety notes when using hazardous substances

 ALWAYS COMPLY WITH THE STIPULATIONS IN THE SAFETY DATA SHEET OF THE MANUFACTURER OF THE COATING SUBSTANCE. IN PARTICULAR, ADHERE TO INSTRUCTIONS RELATING TO:

- THE WEARING OF PERSONAL PROTECTIVE EQUIPMENT.
- THE AVOIDANCE OF EXPLOSIVE OR HARMFUL ENVIRONMENTS.

 ROOMS IN WHICH HAZARDOUS SUBSTANCES ARE STORED OR PROCESSED MUST HAVE ADEQUATE VENTILATION. IT

MAY BE NECESSARY TO INSTALL A TECHNICAL VENTILATION SYSTEM. IF THE VENTILATION SYSTEM FAILS, WORK MUST BE STOPPED IMMEDIATELY!

 DO NOT STORE ANY FLAMMABLE SUBSTANCES, EMPTY COATING SUBSTANCE CONTAINERS OR OTHER MATERIALS THAT HAVE BEEN IN CONTACT WITH THE COATING SUBSTANCE (PAPER, CLOTHS ETC.) WITHIN OR IN THE WORKING ZONE.

 IN THE WORKING ZONE, AVOID OPEN FLAMES AND RED-HOT COMPONENTS AS WELL AS EQUIPMENT, TOOLS AND PARTS THAT CAN CREATE IGNITABLE SPARKS.

 HANG UP "NO SMOKING" SIGNS IN A 5 METRE RADIUS OF THE WORKING ZONE. MAKE FIRE EXTINGUISHERS AVAILABLE IF THESE ARE NOT ALREADY IN PLACE!

 COMPLY WITH ALL NATIONAL AND REGIONAL WATER PROTECTION REGULATIONS.

COMPLY WITH ALL NATIONAL AND REGIONAL WASTE DISPOSAL REGULATIONS.

 FRICTION CHARGING DUE TO FLOWING COATING SUBSTANCES AND/OR COMPRESSED AIR CAN LEAD TO ELECTRIC SHOCKS DUE TO ELECTROSTATIC DISCHARGE!

THE SPRAY GUN MUST THEREFORE BE EARTHED!

WHEN THE GUN IS USED IN POTENTIALLY EXPLOSIVE AREAS, THE AIR AND COATING MATERIAL LINES MUST –BE ELECTRICALLY CONDUCTIVE (<1 MEGAOHM) AND MUST BE EARTHED.

“Airmix”-Installation-plan

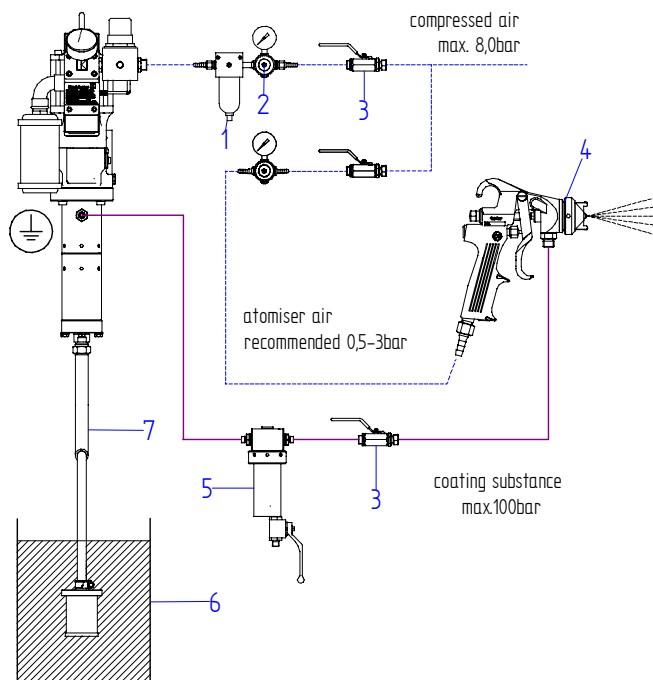

1	Oil- /water seperator
2	Pressure regulator (compressed air)
3	Ball valve
4	Spray gun
5	Filter
6	container

Connections

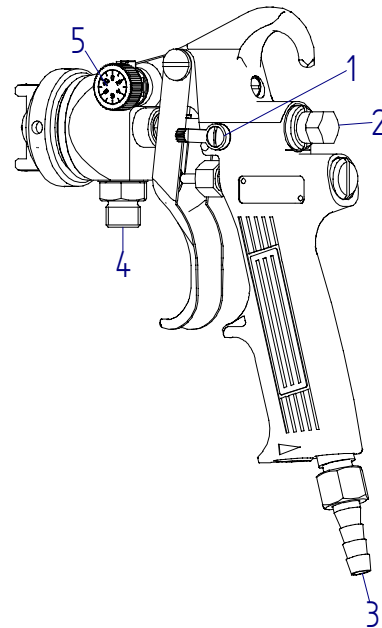

1	Safety catch
2	Needle stroke adjustment
3	Atomiser air
4	Connection nipple coating substance
5	Jet regulator

- Connect atomiser air to item 3
- Material feed to item 4

 ONLY USE HOSES WHICH CAN RELIABLY WITHSTAND THE PRESSURES AND MECHANICAL AND CHEMICAL LOADS DURING OPERATION!

Start-up

- Switch on pump
- Point spray gun at a test surface
- Start spraying process by pressing the trigger
- Switch on atomiser air
- Adjust the spray profile

i A wide range of air and material nozzles in various sizes are available to perform widely differing coating tasks.

There are two different nozzle families:

“Slot air”

“Horn air”

Take the following steps to adjust the spray profile:

- Reduce the pressure of the coating material
- Regulation of atomiser air pressure (0,5-3,0bar recommended)
- with jet regulator
- Setting of needle stroke adjusting screw on the gun
- Choosing the suitable nozzle size

i Excessive air pressure not only leads to unnecessarily high air consumption but also generates heavy misting of the coating substance. It is advisable to first adjust the spray profile by adjusting the air and coating material pressure. If this does not produce a satisfactory profile, you should experiment with different nozzle sizes.

Operational interruptions, cleaning

 ALWAYS ADHERE TO THE INSTRUCTIONS IN THE SAFETY DATA SHEET OF THE DETERGENT MANUFACTURER. DETERGENTS CAN BE HARMFUL TO HEALTH AND EASILY FLAMMABLE!

THE AUTOMATIC SPRAY GUN SHOULD NEVER BE COMPLETELY IMMERSSED IN DETERGENT! THIS COULD DESTROY THE GASKETS AND RINSE OUT THE LUBRICANT!

- The spraying process is terminated by releasing the trigger
- Interrupt coating material feed (switch off pump)
- Clean spray gun (in place of the coating substance, spray a suitable detergent until it emerges clear and without soiling).
- Interrupt detergent feed
- Press trigger to blow out detergent residues
- Interrupt compressed air feed
- Clean externally using a cloth soaked in detergent.

Maintenance

i Please see our catalogue for accessories as well as available air nozzles, material nozzles and needles.

The catalogue is available on the Internet in PDF format (www.krautzberger.com).

 ALL MAINTENANCE WORK MUST BE PERFORMED BY SUITABLY QUALIFIED PERSONNEL!

BEFORE ALL MAINTENANCE WORK:

CLEAN SPRAY GUN, INTERRUPT COMPRESSED AIR FEED AND COATING SUBSTANCE FEED; DISSIPATE ANY RESIDUAL PRESSURE BY OPERATING THE AUTOMATIC SPRAY GUN

i *Check wearing parts like gaskets, nozzles and needles at regular intervals. The level of wear depends on the abrasiveness of the coating substance used. Escaping air and coating substance as well as the deterioration of the spray profile are signs that parts are worn.*

Do not clean material and air nozzles using hard, sharp-edged objects (for cleaning of the nozzles, we recommend our brush set).

The wearing parts are shown in the Appendix.

- Lightly grease sliding parts. We advise you to use Krautzberger special grease for parts that need greasing. This grease is available in 250g cans.
- Always replace material nozzle and material needle together
- Following assembly, ensure that all parts are firmly tightened/connected
- Check moving parts for smooth motion

Technical data

Pressure, temperature

Max material pressure	10 MPa	100 bar
Max. material temperature:	50 °C	
Max. atomiser air pressure	0,8 MPa	8 bar
		<i>0,5-3,0bar recommended</i>
Max. compressed air temperature:	50 °C	

Connections

Coating substance:	G1/4a
Atomiser air	G1/4i
Control air	G1/4i

Weight ca. 630 g

Noise level

(nozzle-dependent) 60 bis 90 dB (A)

Spare parts drawing

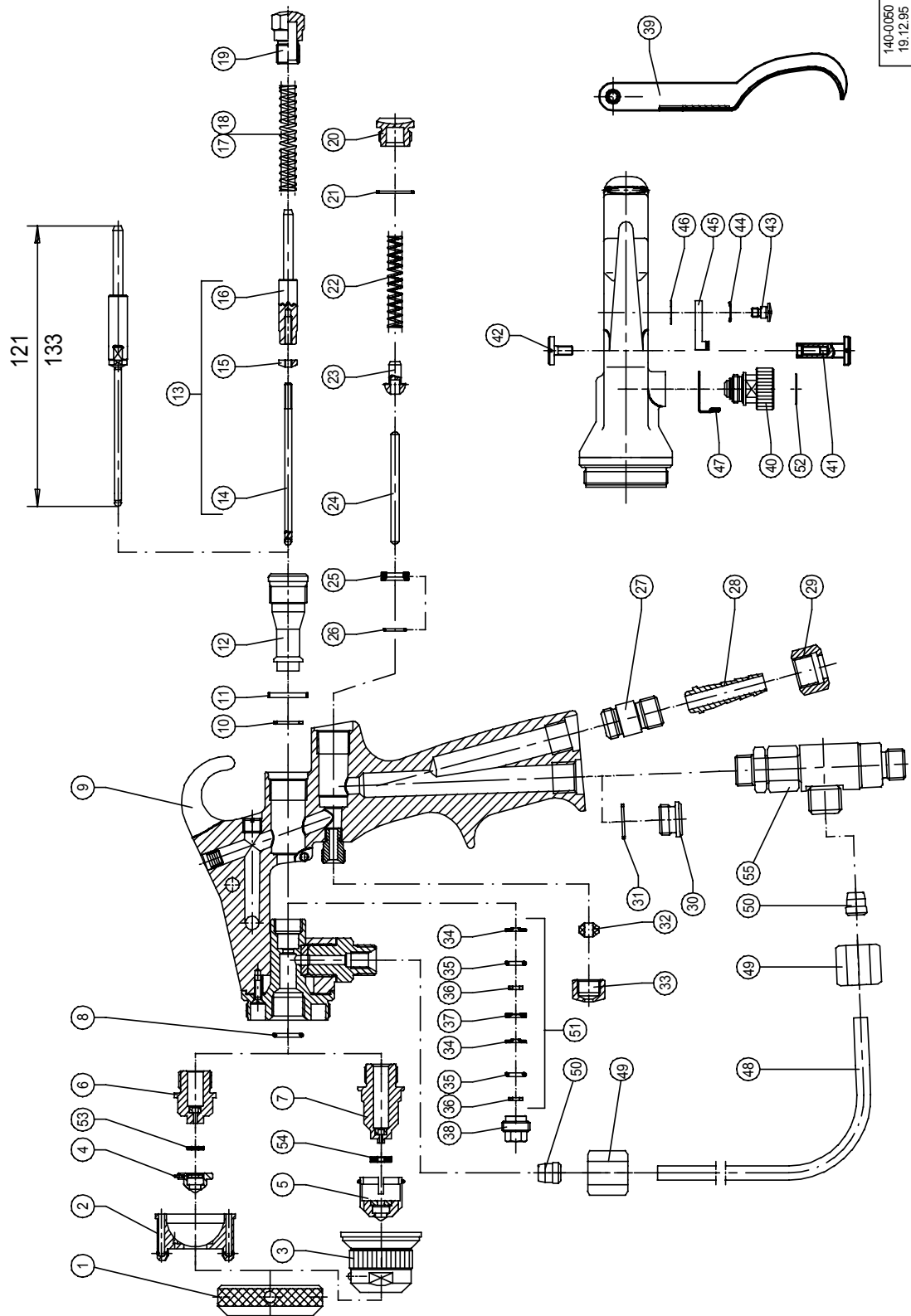

Item	Designation	Order-no.
1	Clamping nut	3210-040-0829
2	Air cap "horn"	3200-060-0295
3	Air cap "slot"	3210-060-0294
4■	Material nozzle	3200-050-....
5■	Material nozzle	3210-050-....
6	Valve seal screw	3200-080-0379
7	Valve seal screw	3210-080-0970
8	Gasket	3200-010-0046
9	Main element Main element incl. material pipe (incl. 48, 49, 50, 55)	3200-080-0587 3204-080-1226
10	Gasket	3200-010-0377
11	Gasket	3200-010-0376
12	Threaded insert	3200-040-0102
13	Valve needle, cpl. 121mm Valve needle, cpl. 133mm	3200-070-0779 3210-070-0780
14	Valve needle, 70mm Valve needle, 80mm	3200-070-0775 3210-070-0777
15	Needle pusher	3200-070-0727
16	Needle bolt	3200-040-0088
17	Spring (<i>material pressure 0-80bar</i>)	3200-020-0034
18	Strengthened spring (<i>material pressure 80-100bar</i>)	3200-020-0033
19	Screw	3200-040-1053
20	Screw	3200-040-1722
21	Gasket	3200-010-0378
22	Spring	3200-020-0010
23	Sealing mushroom	3200-040-1728
24	Valve axis	3200-040-0625
25	Gasket	3200-010-0381
26	Gasket	3200-010-0512
27	Double nipple	6920-030-2239
28	Hose clip	6902-040-0822
29	Union nut	6902-040-0821
30	Screw	3200-040-1373
31	Gasket	3200-010-0379
32	Gasket	3200-010-0007
33	Nut	3200-040-0658
34	Gasket (2pcs)	3200-010-0339
35	Gasket (2pcs)	3200-010-0043
36	Guide ring	3200-040-2013
37	Spacer ring	3200-040-1231
38	Screw	3200-040-1232
39	Trigger	3200-040-1863
40	Jet regulator	3200-080-0485
41	Trigger shaft	3200-040-1696
42	Screw	3200-030-1373
43	Screw	3200-040-1233
44	Lock washer	3200-040-1646
45	Safety catch	3200-040-1643
46	Disk	3200-040-1645
47	Detend spring	3200-020-0024
48	Material pipe	3204-040-2566
49	Nut (2pcs)	3204-030-0851
50	Cutting ring	3204-030-0850
51	Needle packing, cpl.	3200-010-0707
52	Scale disk	3200-040-0212
53	Gasket	3200-010-0057
54	Gasket	3210-010-0047
55	Material connection, cpl.	3204-080-2285
	Gasket set	3200-010-0631
■ Please state type and size when ordering		

Accessories

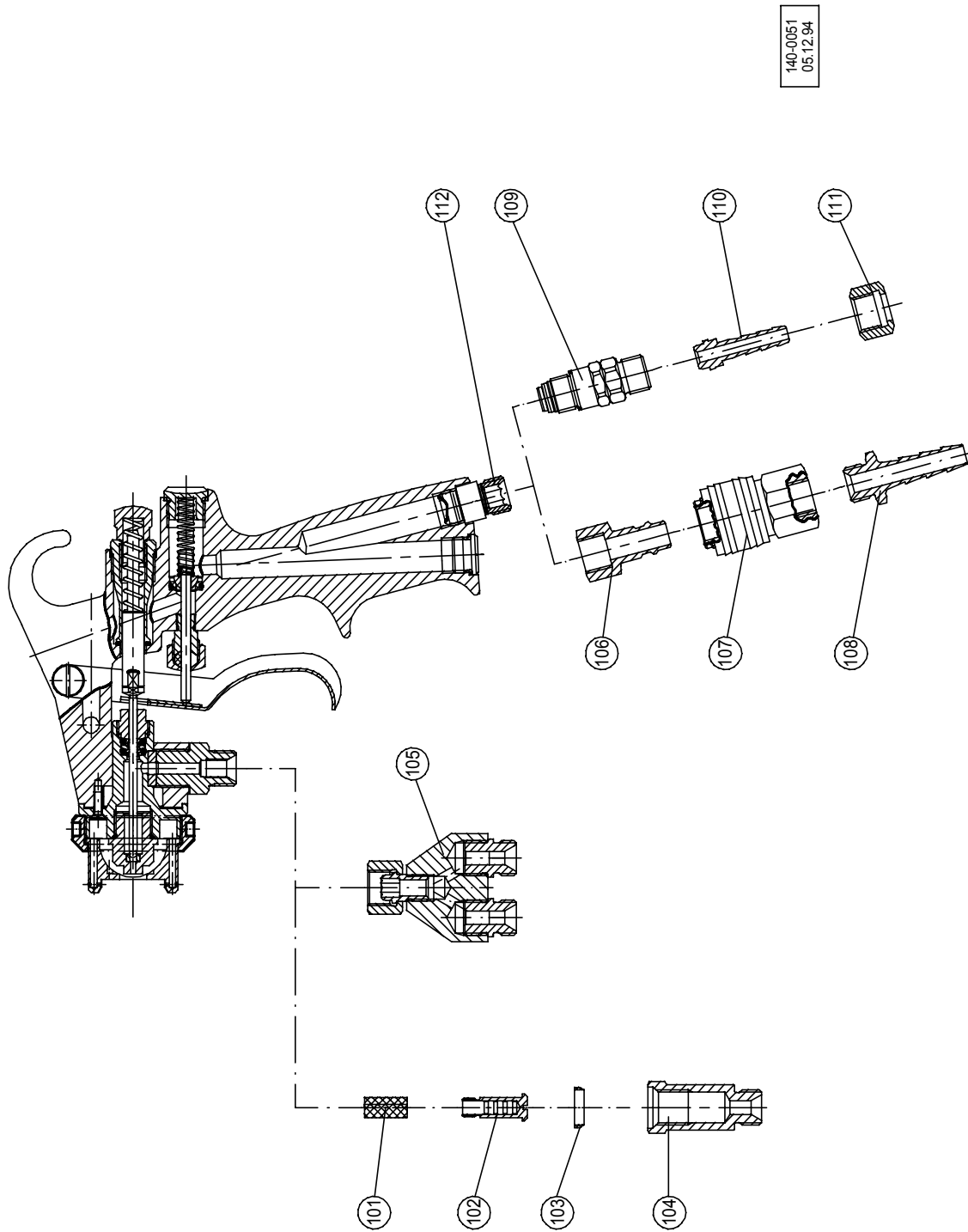

Item	Designation	Order.No.
101■	Filter mesh	3201-030-....
102	Mesh screw	3201-040-1051
103	Gasket	3201-010-0045
104	Mesh housing	3201-040-1052
105	Circulation material connection	3203-040-1061
106	Clutch nipple, brass	6901-030-2272
107	Fast coupling, brass	6901-030-2330
108	Hose nozzle Ø8/9	6901-040-0666
108	Hose nozzle Ø6/7	6901-030-2209
109	Pivoted air connection	3200-080-0527
110	Hose nozzle Ø6/7	60902-040-0823
111	Union nut	6902-040-0821
112	Double nipple	6920-030-2239
	Tool set	7026-120-0059

■ Please state mesh size when ordering (available sizes: 0,06 / 0,07 / 0,08 / 0,09 / 0,15 / 0,20 / 0,30)