

Operating instructions / Spare parts list

DOK-275-GB.doc Rev. 1

Designation Piston pump

Type 11-115

Order-No.: 7262-000

- keep for further use -

CE

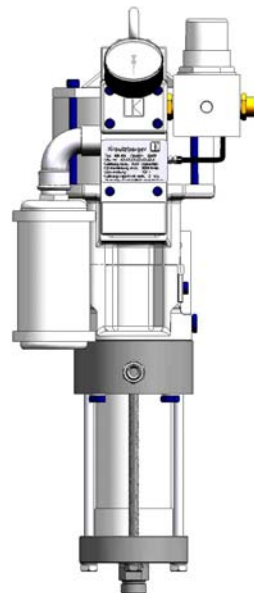

Krautzberger 

CONTENT

1	The Airless process	2
2	Method of operation of the positive-displacement pump	2
3	General safety notes	2
3.1	Important when using hazardous substances:	3
4	Mounting and installation	4
5	Start-up	4
6	Switching off.....	5
7	Maintenance	5
8	Trouble shooting guide	6
9	Installation plan	7
10	Units of the piston pump	8
11	Technical data.....	9
12	Spare parts	10
12.1	Motor M 170	10
12.2	Control unit	12
12.3	Hydraulic part	14
12.4	Rinsing chamber and fastener	16
12.5	Fluid strainer	18
12.6	Suction hose	20

1 The Airless process

Atomization and agent application are brought about without the use of air, thus the term Airless. The agent is being atomized by squeezing it under an extremely high pressure through the small bore of the material nozzle. In the process the agent is disintegrated into individual particles.

The pressure required for the Krautzberger Airless process may attain up to **480bar** and is generated by compressed air operated positive-displacement piston pumps.

Advantages of the Airless spray

- upgrated spray performances
- instant surface coating due to a full and saturated homogeneous spray pattern and instant film formation
- reduced spray time
- increased material yield due to minimized spray fogs and low material rebound.

- fatigueless working brought about by a light and handy spray gun design equipped with only on material supply hose
- optimized atomisation even of high viscous materials

2 Method of operation of the positive-displacement pump

By means of an independently controlled air motor which is alternately applying pressure onto the motor piston, the recuperator piston of the pump is moved upwards and downwards.

Air motor and recuperator piston are interconnected via an coupling system.

Whilst moving upwards the suction valve is opened and the agent is sucked into the lower chamber of the hydraulic unit. Simultaneously the pressure valve located in the piston is being closed and the recuperator piston feeds the agent into the hydraulic unit.

The set spray pressure and the adopted nozzle size determine the stroke frequency, the air consumption. and thus the respective spray performance of the positive-displacement pump.

All agent conveying pump components consist of special steel 18/8

3 General safety notes

EACH TIME BEFORE YOU START WORKING, CHECK THE FIRM SEAT OF THE AIR AND MATERIAL CONNECTIONS!

EACH TIME BEFORE YOU START WORKING, CHECK THE HOSE LINES FOR WEAR AND DAMAGE!

LOOSE, PRESSURISED HOSES MAY CAUSE ACCIDENTS DUE TO WHIPLASH-LIKE MOVEMENT AND THE DISCHARGE OF FLUIDS.

HIGHLY ABRASIVE, CHEMICALLY AGGRESSIVE, EXTREMELY HOT OR EX-

TREMELY COLD MATERIALS MAY ONLY BE USED IN CONSULTATION WITH KRAUTZBERGER GMBH!

PISTON PUMPS MAY ONLY BE USED IN LINE WITH THE OPERATING PARAMETERS (PRESSURE, TEMPERATURE ETC.) SPECIFIED UNDER "TECHNICAL DATA"!

THE OPERATOR MUST CHECK THE COMPATIBILITY OF THE PUMP MATERIALS WITH THE COATING SUBSTANCE TO BE USED. TO ENSURE COMPATIBILITY, REFER TO THE SAFETY DATA SHEET SUPPLIED BY THE MANUFACTURER OF THE COATING SUBSTANCE!

ALL WORK CONNECTED WITH INSTALLATION AND MAINTENANCE MUST BE PERFORMED BY SUITABLY QUALIFIED PERSONNEL. ALWAYS USE ORIGINAL PARTS WHEN REPLACING WORN OR DAMAGED PARTS.

NEVER POINT COMPRESSED AIR AT PEOPLE OR ANIMALS!

3.1 Important when using hazardous substances:

ALWAYS COMPLY WITH THE STIPULATIONS IN THE SAFETY DATA SHEET OF THE MANUFACTURER OF THE COATING SUBSTANCE. IN PARTICULAR, ADHERE TO INSTRUCTIONS RELATING TO:

- **THE WEARING OF PERSONAL PROTECTIVE EQUIPMENT**

THE AVOIDANCE OF EXPLOSIVE OR HARMFUL ENVIRONMENTS

ELECTROSTATIC CHARGES DURING OPERATION OF THE PUMP CAN LEAD TO ELECTRIC SHOCKS AND SPARK FORMATION.

THE PUMP MUST THEREFORE BE EARTHED!

ALSO EARTH AIR PIPES, OPERATING EQUIPMENT AND ELECTRICALLY CONDUCTIVE SURFACES IN THE WORKING ZONE.

CONNECTED HOSE LINES MUST BE CONDUCTIVE (<1 MEGA-OHM) AND MUST ALSO BE EARTHED.

ROOMS IN WHICH HAZARDOUS SUBSTANCES ARE STORED OR PROCESSED MUST HAVE ADEQUATE VENTILATION. IT MAY BE NECESSARY TO INSTALL A TECHNICAL VENTILATION SYSTEM.

IF THE VENTILATION SYSTEM FAILS, WORK MUST BE STOPPED IMMEDIATELY AND THE PUMP SWITCHED OFF.

IN SUCH CASES, ALWAYS COMPLY WITH THE NATIONAL AND REGIONAL REGULATIONS.

DO NOT STORE ANY FLAMMABLE SUBSTANCES, EMPTY COATING SUBSTANCE CONTAINERS OR OTHER MATERIALS THAT HAVE BEEN IN CONTACT WITH THE COATING SUBSTANCE (PAPER, CLOTHS ETC.) IN THE WORKING ZONE OF THE PUMP.

DO NOT USE HALOGENATED DETERGENTS. CHEMICAL REACTIONS MAY CREATE EXPLOSIVE AND CAUSTIC COMPOUNDS!

IN THE WORKING ZONE, AVOID OPEN FLAMES AND RED-HOT COMPONENTS AS WELL AS EQUIPMENT, TOOLS AND PARTS THAT CAN CREATE IGNITABLE SPARKS.

HANG UP "NO SMOKING" SIGNS IN A 5 METRE RADIUS OF THE WORKING ZONE!

MAKE FIRE EXTINGUISHERS AVAILABLE IF THESE ARE NOT ALREADY IN PLACE!

COMPLY WITH ALL NATIONAL AND REGIONAL WATER PROTECTION REGULATIONS!

COMPLY WITH ALL NATIONAL AND REGIONAL WASTE DISPOSAL REGULATIONS!

4 Mounting and installation

 **THE COMPRESSED AIR SUPPLY MUST BE DRY AND OIL-FREE !!!**

The Airless pump is to be installed in such a way as to render it easily accessible for maintenance and cleaning purposes.

The pump holder is provided with an earthing screw to which the ground wire must be connected in order to ground the static charge generated by the agent flowing within the hose.

Connect the Airless pump only with a heavy duty compressed-air supply net: designed for a maximum compressed air consumption.

PRIOR TO START-UP, CLOSE THE PRESSURE REGULATOR OF THE AIRLESS PUMP BY COUNTER-CLOCKWISE TURNING THE HAND-WHEEL.

The piping supplying compressed air to the Airless-pump should have a nominal width of 9.

Furthermore we recommend to provide the compressed air supply net with an oil- and water separator in order to prevent foreign bodies from penetrating into both air motor and independently operating control system.

If need be a compressed air-oiler with deicing agent maybe installed between airless pump and oil/water separator.

Use only the original suction gear in order to ensure proper pump sucking.

Engage spray gun`s safety catch and connect the material supply hose at the outlet of the high-pressure filter.

WHEN IT COMES TO MATERIAL SUPPLY HOSES WITH SAFETY CONDUCTOR IN ORDER TO PREVENT ELECTROSTATIC CHARGES FROM BEING GENERATED.

CAUTION:

With regard to operating the Airless pump we prefer to the safety rules edited and published by the applicable employers liability insurance.

5 Start-up

- Entirely close pressure regulator at motor
- connect compressed air-hose (max. 6bar)
- in case the pump is provided with a material filter, (strongly recommended by us) a filter mesh matching the nozzle requirements must be used. See table
- Fill rinsing agent into the rinsing chamber, until the sight glass shows a 70% fillin level
- Slowly open pressure regulator until air motor starts working.
- Rinse the Airless pump by means of the rinsing agent in order to get the preservatives out of the pump
- put the suction hose into the spray agent
- open spray gun in order to evacuate the air still contained in the system
- When the spray agent starts to emerging from the spray gun, close spray gun and set the required working pressure at the pressure regulator (max 6bar)

CAUTION!

PAY ATTENTION TO THE PRESSURE TRANSFORMATION RATIO!

Under no-load conditions the Airless-pump must only be operated for a short time and at a slow running level.

Otherwise motor, suction valve, piston valve and the pump sealing may be damaged.

CAUTION!

The spray jet emerging from the spray gun is dangerous. For this reason aim the spray gun only downwards.

6 Switching off

Switching-off

- Entirely close pressure regulator at motor
- disconnect spray gun and render the system pressureless.
- remove and clean the spray nozzle
- remove suction hose out of the spray agent and put it in a thinner
- slowly open pressure regulator whilst the spray gun is being opened, until the air motor starts working
- rinse spray gun and pump by means of a thinner. In the process make sure that the motor runs at a slow level only
- for rough cleaning of the filter during rinsing , shortly open the cock at filter

7 Maintenance

Daily check rinsing agent level during operation. Sight glass must show a 70% filling level.

In case the rinsing agent is contaminated by the spray agent, replace the rinsing agent. If, after a short time only, the rinsing agent should again be contaminated or should the rinsing agent level displayed by the sight glass increase, we recommend to replace the gaskets set in the hydraulic section.

By replacing these gasket sets, the recuperator piston prevented from being worn out prematurely.

We recommend to open the material filter at fixed intervals in order to clean the filter housing, mesh inclusive.

CAUTION!

Prior to opening material filter refer to instructions

8 Trouble shooting guide

kind of mal- function origin of mal- function (unit)	pump does not start or Stopps running durin operation	no or insufficient pump sucking	spray pres- sure to low	uneven op- eration of pump	pump con- tinues run- ning even though spray gun is closed	pump feeds agent into rinsing chamber	iced control
Drive	clean control and defective parts			clean control and defective parts			pump runs too fast
hydraulic unit		insufficient venting, leaking screwing between hydraulic unit and suction gear		insufficient venting, leaking screwing between hydraulic unit and suction gear			
suction gear		mesh basket obstructed		mesh basket obstructed			
high pressure filter	filter contaminated, check for passage and cleanliness						
high pressure material hose	choked hose, check for passage and cleanliness						
suc- tion/pressure valve		worn or blocked, replace defective parts					
sealing sets		leaking gaskets				upper gasket set leaking	
atomizer nozzle	nozzle bore choked		excessive nozzle bore				excessive nozzle bore
pressure re- ducing valve	air pressure too low		air pressure too low				
compressed air piping	insufficient air quantity, air pressure too low		insufficient air quantity, air pressure too low				
spray agent		viscosity too high					

9 Installation plan

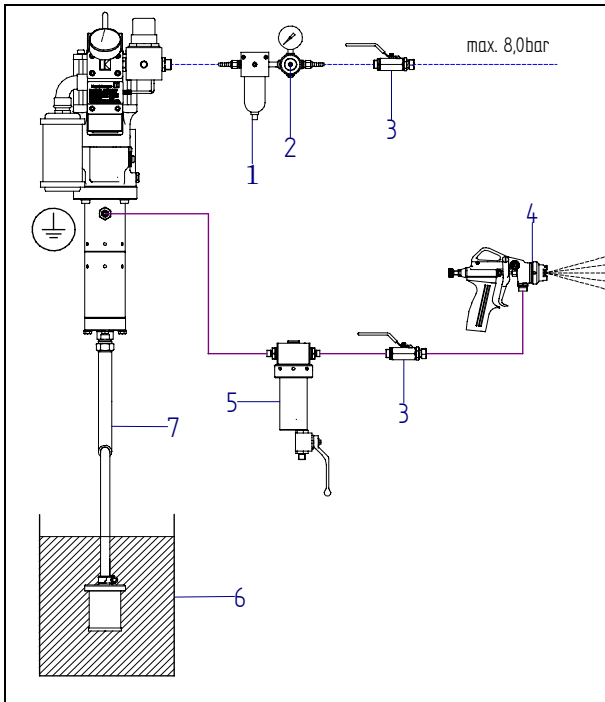

1	Oil- / Water seperator
2	Pressure regulator
3	Ball valve
4	Spray gun
5	Fluid strainer
6	Container
7	Suction hose with mesh

10 Units of the piston pump

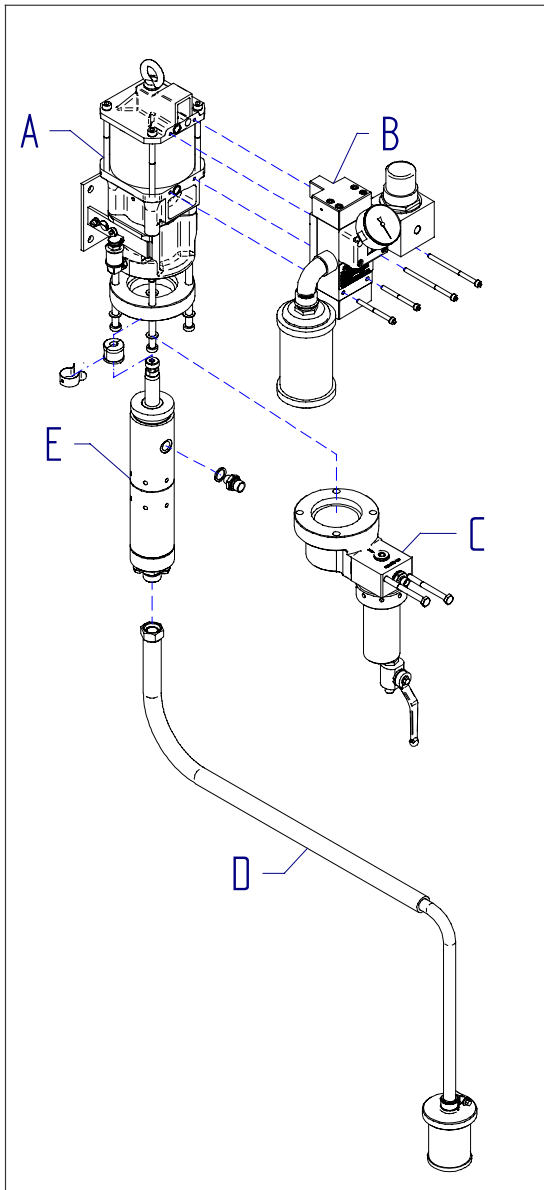

A	Air motor and fastener
B	Control unit
C	Fluid strainer (optional)
D	Suction hose
E	Hydraulic part

11 Technical data

Air consumption

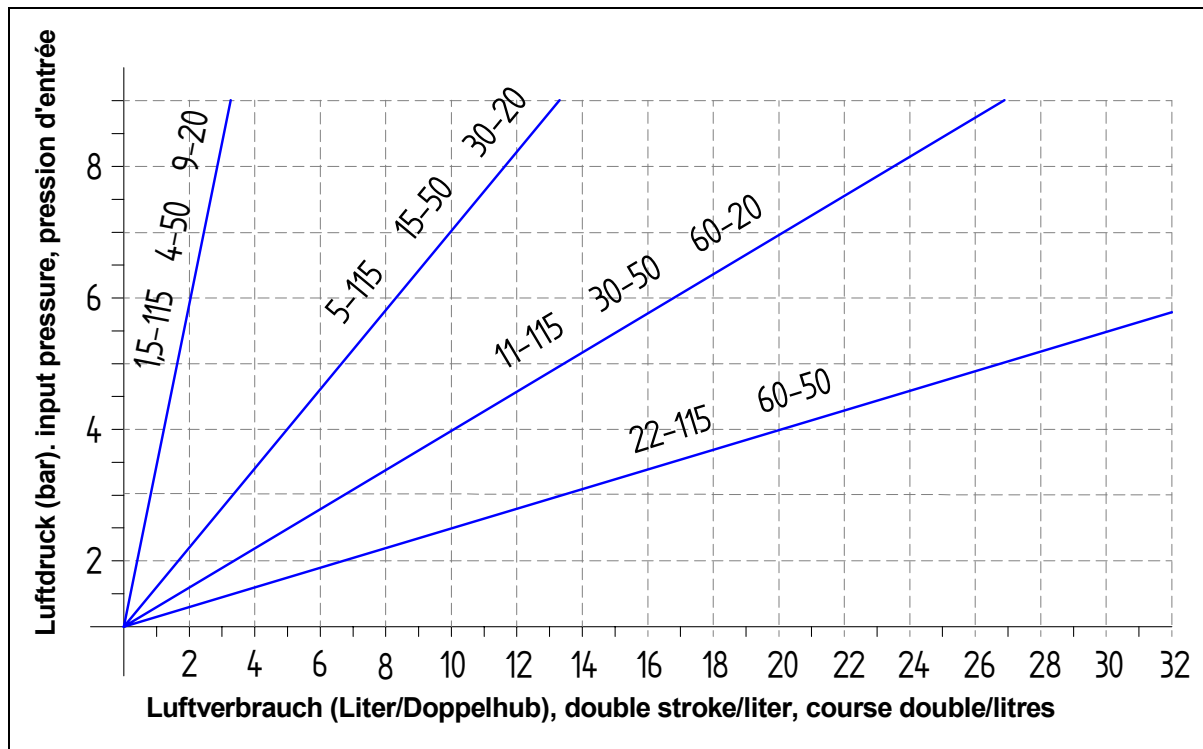

Typ	Transformation ratio	volume (ccm)	Max. rec. Double strokes per minute	Max. compressed air supply pressure	Max. fluid pressure	Recc. Delivery rate (l/min ²)	max. delivery rate (l/min ¹)
30-10	30:1	20	50	8	240	1,0	2,0
9-20	9:1	40	50	8	72	2,0	4,0
30-20	30:1	40	50	8	240	2,0	4,0
60-20	60:1	40	50	8	480	2,0	4,0
4-50	4:1	100	50	8	32	5,0	10,0
15-50	15:1	100	50	8	120	5,0	10,0
30-50	30:1	100	50	8	240	5,0	10,0
60-50	60:1	100	50	8	480	5,0	10,0
1-115	1,5:1	230	50	6	9	11,5	23,0
5-115	5:1	230	50	6	30	11,5	23,0
11-115	11:1	230	50	6	66	11,5	23,0
22-115	22:1	230	50	6	132	11,5	23,0

⁽²⁾ (50 double strokes/minute) ⁽¹⁾ (100 double strokes/minute)

12 Spare parts

12.1 Motor M 170



„x“lightly grease parts (for example "Klübersynth UH1 14-31")

„xxx“ parts should be bonded (for example Loctite 245)

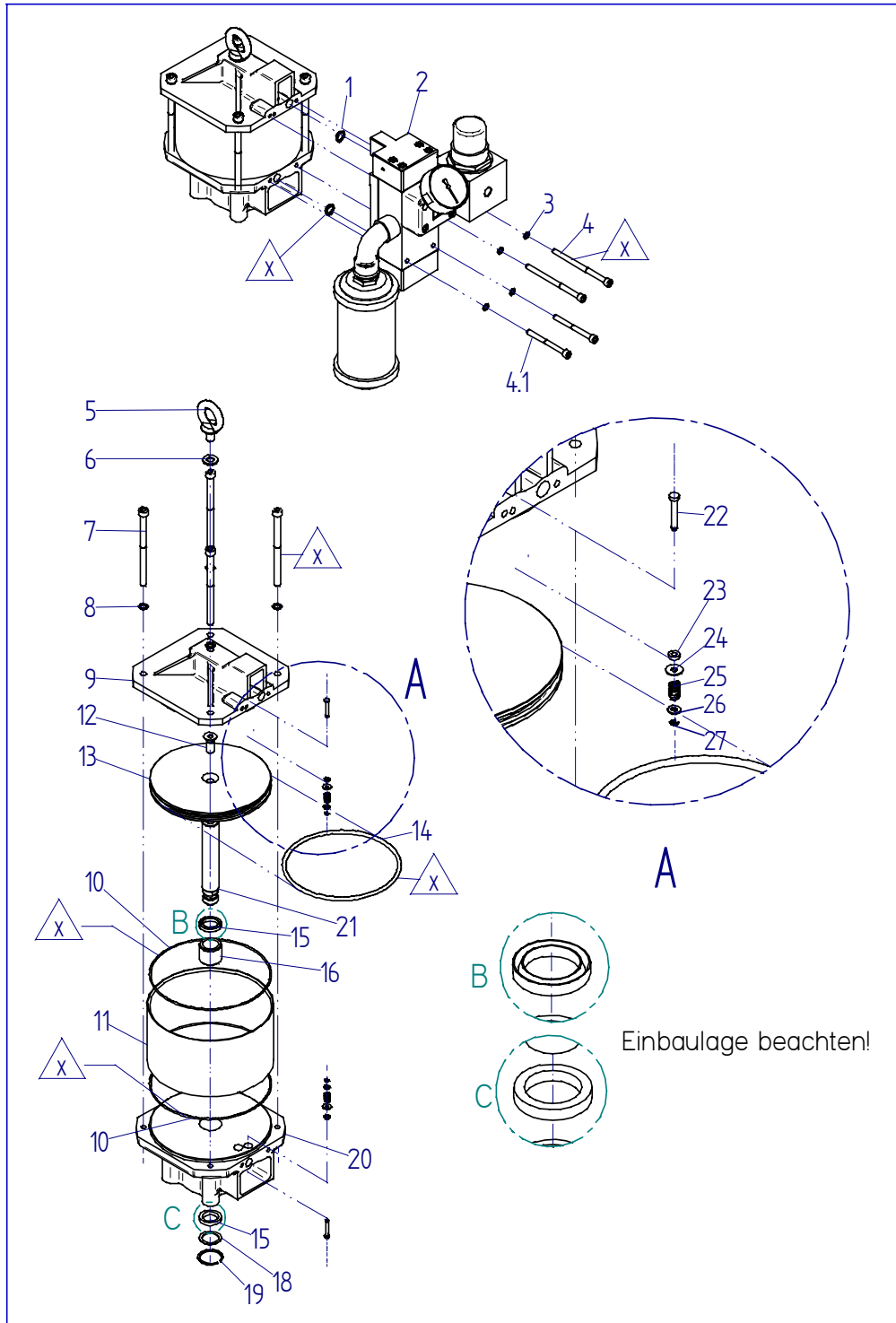

Motor M-170

Item	Designation	Order-No.	QTY
1	O-ring, NBR 70	010-0241	2
2	Control section, cpl.	080-3141	1
3	Circlip, stainless steel	030-0706	4
4	Cap screw, M6x100	030-0315	2
4.1	Cap screw, M6x70	030-0310	2
5	Eye bolt	030-0143	1
6	Washer	030-2867	1
7	Cap screw, M8x115	030-0512	4
8	Circlip,	030-0714	4
9	Upper part motor	040-0026	1
10	O-ring, NBR 70	010-0259	2
11	Cylinder tube	040-0031	1
12	Countersunk screw M10x25	030-0354	1
13	Piston	040-0032	1
14	O-ring, NBR 80	010-0258	1
15	slotted ring, NBR 90	010-0898	2
16	bearing bush	040-0041	1
18	Pulley	040-0042	1
19	Circlip	030-0718	1
20	Lower part motor	040-0445	1
21	piston rod	040-0030	1
22	tappet rod	040-0034	2
23	slotted ring, NBR 90	010-0247	2
24	Washer	030-2857	2
25	pressure spring, stainless steel	020-0076	2
26	Washer	030-2856	2
27	Stop washer	030-0719	2

12.2 Control unit

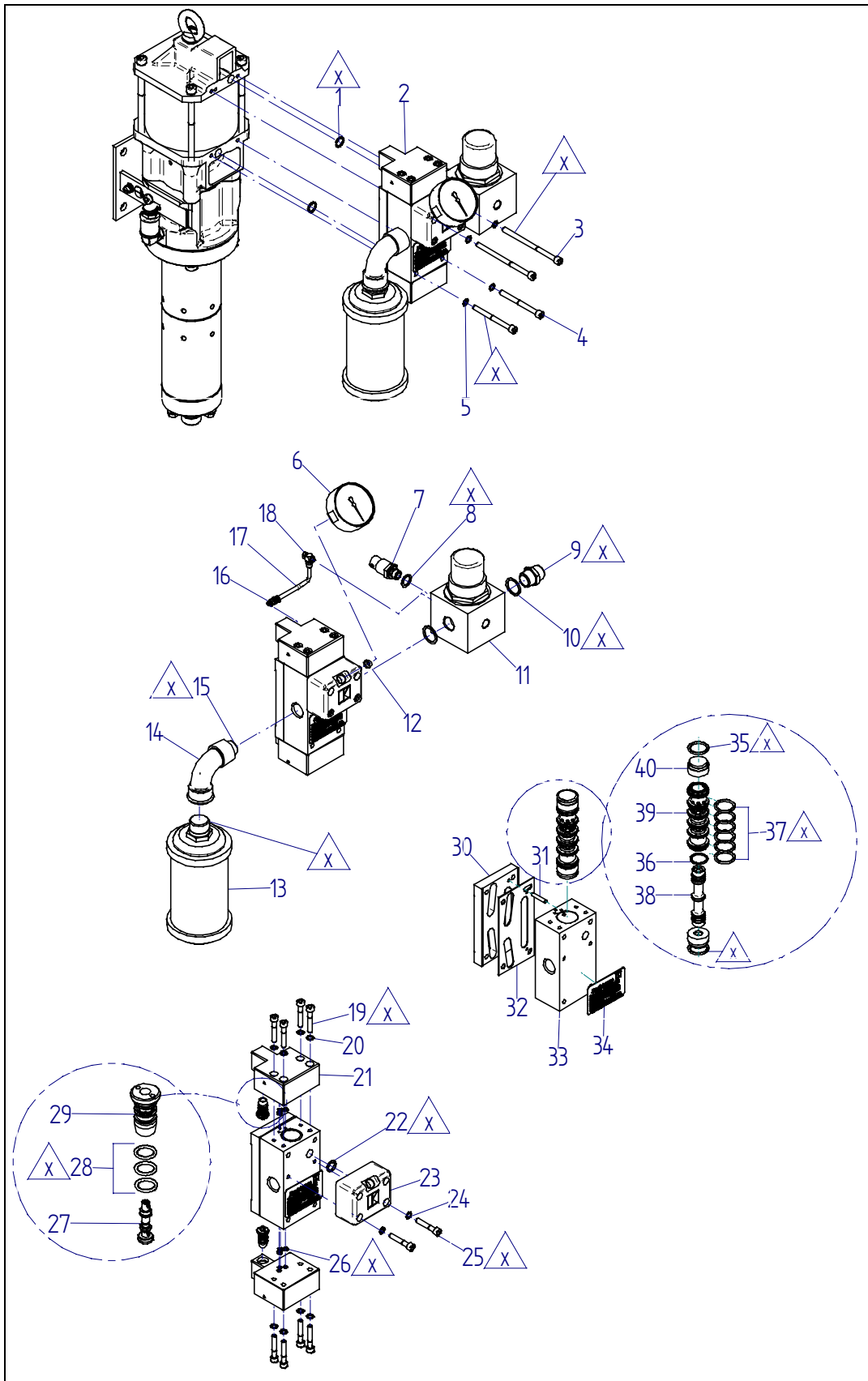

Control unit

Item	Designation	Order-No.	QTY
1	O-ring NBR 70	010-0241	2
2	Control valve, complete	130-0305	1
3	Screw M6x95 (M-70) Screw, M6x100	030-0533 030-0315	2
4	Screw M6x68 (M-70) Screw, M6x70	040-4896 030-0310	2
5	Washer, VA 1.4122 für Schraube M6	030-0706	4
6	Pressure gauge, 10bar	030-0720	1
7	Mini-safety valve 8,0bar Mini-safety valve 6,0bar	130-0179 030-2838	1 1
8	Flat gasket, copper	010-0244	1
9	double nipple, brass 2xG3/4"	030-1991	2
10	Flat gasket, copper	010-0287	2
11	Compressed air regulator	030-1313	1
12	Gasket, aluminium	010-0251	1
13	Sound absorber	030-0711	1
14	Bend, short	030-2020	1
15	Extension, IG3/4"-AG1/2"	030-0708	1
16	Rapid screw connection, brass, PH 3-5	030-2406	1
17	Hose, max. 8bar, l=82mm	010-0439	1
18	Swivel screw connection, brass, PH3-5	080-0207	1
19	Screw, M6x35	030-0294	8
20	Circlip	030-0706	8
21	Housing, valve	040-4618	2
22	O-ring, NBR 70	010-0243	1
23	Fittiing	040-0446	1
24	Washer, stainless steel	030-0706	2
25	Screw, M6x35	030-0294	2
26	O-ring, NBR 70	010-0636	6
27	Control piston	010-0835	2
28	O-Ring, EPDM	010-0188	6
29	Pick-up sleeve	040-3902	2
30	Air distributor	040-0316	1
31	Spring pin	030-2720	1
32	Flat gasket	010-0245	1
33	Housing control valve	040-4617	1
34	Type plate	040-1874	1
35	O-ring, NBR 70	010-0352	2
36	O-ring, NBR	010-0741	1
37	O-ring, NBR 70	010-0352	6
38	Pusher, aluminium	030-3852	1
39	Inner part for control valve, brass	030-4141	1
40	Spacer	040-3329	2

12.3 Hydraulic part

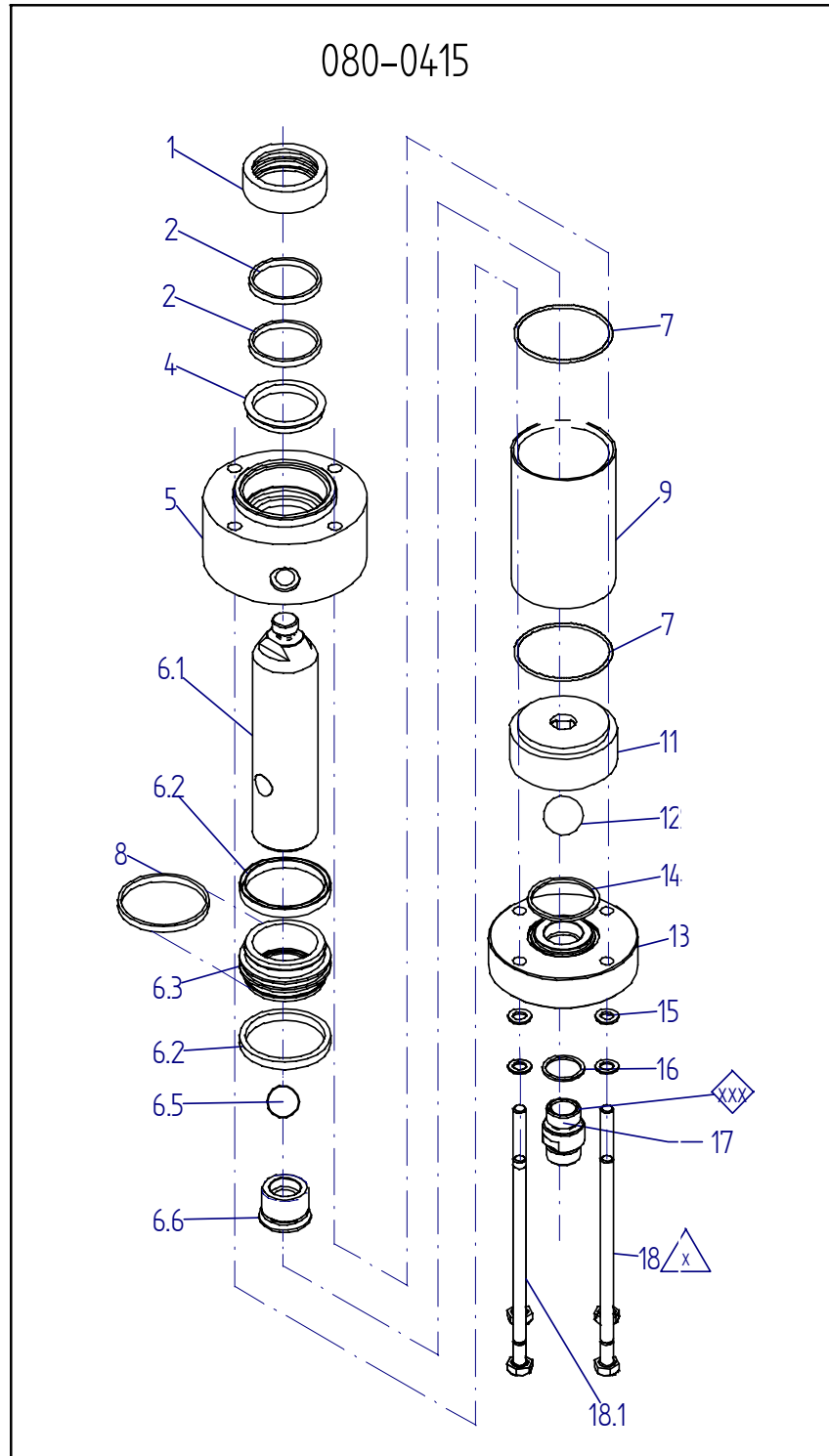

Hydraulic part 090-0005

Item	Designation	Order-No.	QTY
1	Adapter	040-0024	1
▲ 2	Guide band, 162mm	030-1884	2
▲ 4	Slotted ring with collar, UHMW-PE	010-0374	1
5	Pump upper part	040-0011	1
6	Piston, complete	080-0118	1
6.1	Piston	040-0017	1
▲ 6.2	Slotted ring with collar, UHMW-PE	010-0371	2
6.3	Piston base	040-0019	1
6.5	Ball, stainless steel	030-0700	1
6.6	Sealing plug, complete	080-0119	1
▲ 7	O-Ring, viton	010-0373	2
▲ 8	Guide band, 211mm	030-0703	1
9	Hydraulic tube	040-0012	1
11	Pump lower part	040-0013	1
12	Ball, stainless steel	030-0701	1
13	Pump fastener, complete	080-0117	1
▲ 14	Axial gasket, UHMW-PE	010-0264	1
15	Washer, stainless steel	030-2875	4
▲ 16	Flat gasket, copper	010-0288	1
17	Double nipple G3/4" AG	040-0025	1
18	Hexagonal screw, M-10x190 (3 pcs.)	030-0652	3
18.1	Hexagonal screw, M-10x184,5 (1 pcs.)	040-0056	1
▲	Gasket set	010-0865	

12.4 Rinsing chamber and fastener

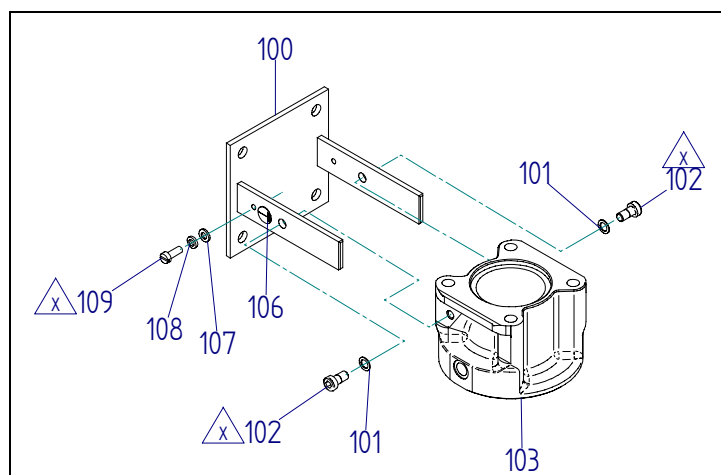
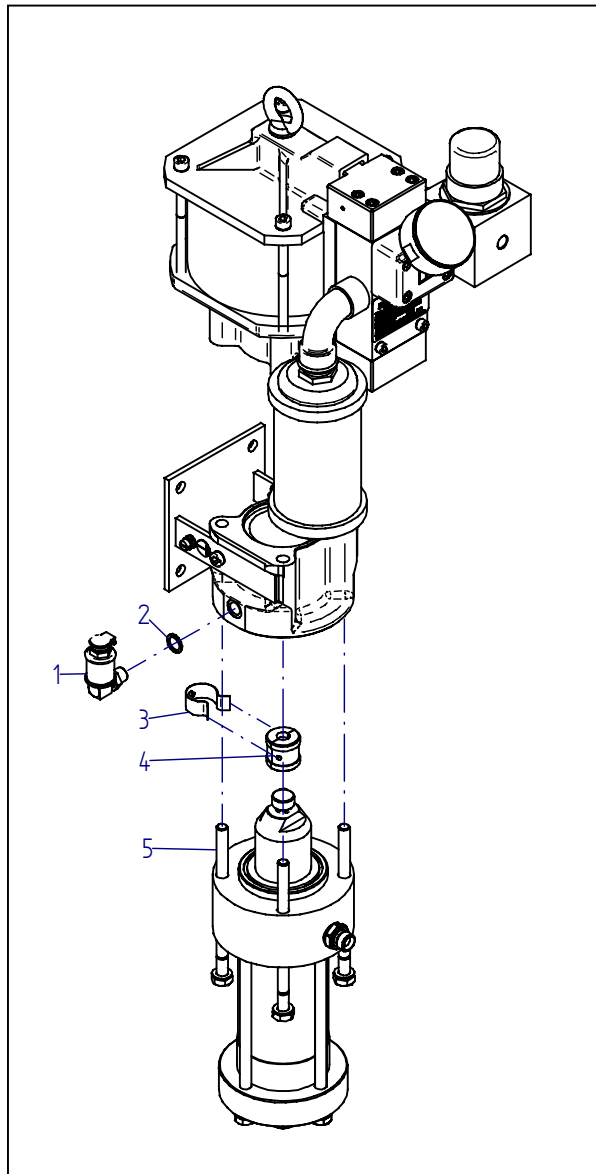

Rinsing chamber and fastener

Ítem	Designation	Order-No.	QTY
1	Fill in sight glass	030-1879	1
2	Flat gasket	010-0244	1
3	Spring	020-0150	1
4	Coupling	040-0062	1
5	Cheese head screw M-10x160	030-2963	4
100	Pump bracket	080-0006	1
101	Circlip	030-0714	2
102	Cheese head screw M8x16	030-0524	2
103	Rinsing chamber X/20	040-0060	1
106	Label "Protection earth"	040-1878	1
107	Washer, brass	030-2863	1
108	Serrated lock washer	030-2894	1
109	Cheese head screw M6x16	030-0274	1

12.5 Fluid strainer

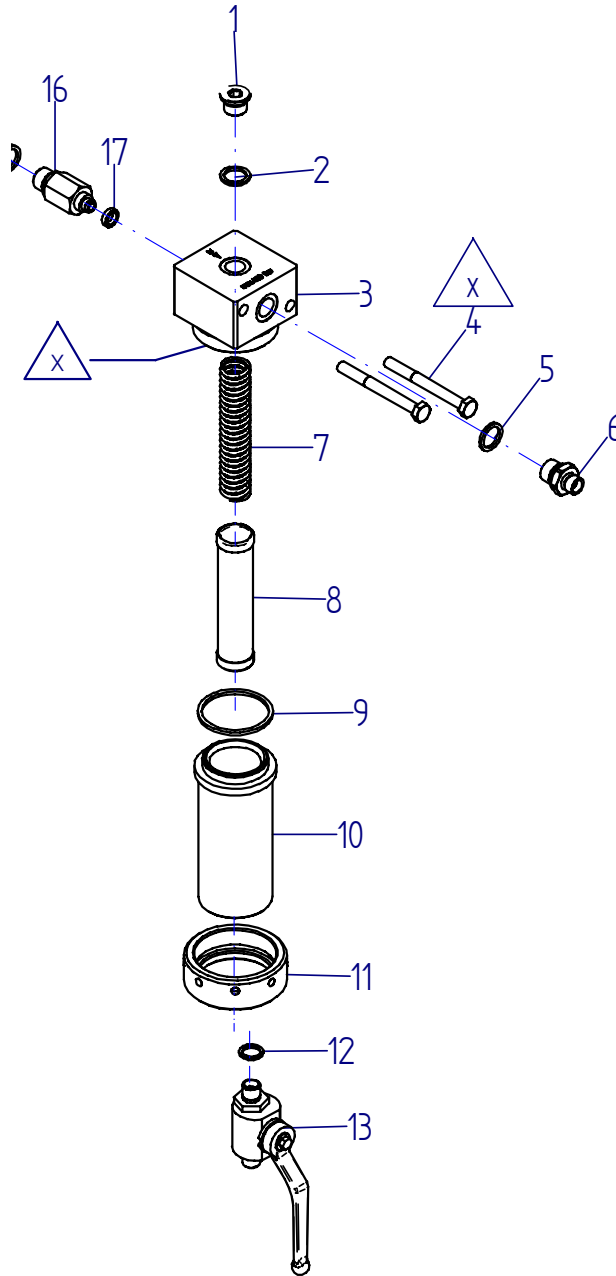

Fluid strainer

(optional accessories)

Item	Designation	Order-No.
1	Sealing plug	030-0526
2	Flat gasket, copper	010-0260
3	Adapter	040-0462
4	Cap screw, M8x80	030-0515
5	Flat gasket, copper	010-0260
6	Double nipple	040-0601
7	Support spring	020-0056
8	<i>Filter mesh size 0, (0,02mm)</i>	<i>030-3258</i>
	<i>Filter mesh size 1, (0,06mm)</i>	<i>030-1427</i>
	<i>Filter mesh size 2, (0,075mm)</i>	<i>030-1428</i>
	<i>Filter mesh size 3, (0,08mm)</i>	<i>030-1429</i>
	<i>Filter mesh size 4, (0,09mm)</i>	<i>030-1430</i>
	<i>Filter mesh size 6, (0,20mm)</i>	<i>030-1431</i>
	<i>Filter mesh size 9, (0,25mm)</i>	<i>030-1432</i>
	<i>Filter mesh size 12, (0,30mm)</i>	<i>030-1433</i>
	<i>Filter mesh size 15, (0,40mm)</i>	<i>030-1434</i>
	<i>Filter mesh size 20, (0,51mm)</i>	<i>030-1435</i>
9	Axial gasket, UHMW-PE	010-0264
10	Filter housing	040-0463
11	Nut	030-1452
12	Flat gasket	010-0244
13	Ball cock	030-0960
16	Connection nipple 1/4"	040-0601
	Connection nipple 3/8"	040-0061
17	Flat gasket, copper	010-0260

