

## Operating instructions and spare parts list

DOK-268-GB Rev. 1

**designation**                      **airless spray appliance**

**type**                                      **4-50**

**Order-No.: 7200-000**

- keep for further use -



	<b>Dokumentation</b> DOK-268-GB.doc Rev.0	Bezeichnung	HD-Pumpe
		Typ	4-50
		Artikel	7200-000

### Caution!

**Use the high-pressure pump only with dry, unlubricated compressed air!**

### The Airless process

Atomization and agent application are brought about without the use of air, thus the term Airless. The agent is being atomized by squeezing it under an extremely high pressure through the small bore of the material nozzle. In the process the agent is disintegrated into individual particles.

The pressure required for the Krautzberger Airless process may attain up to **480bar** and is generated by compressed air operated positive-displacement piston pumps.

### Advantages of the Airless spray

- upgrated spray performances
- instant surface coating due to a full and saturated homogeneous spray pattern and instant film formation
- reduced spray time
- increased material yield due to minimized spray fogs and low material rebound.
- fatigueless working brought about by a light and handy spray gun design equipped with only on material supply hose
- optimized atomisation even of high viscous materials

## 1 Method of operation of the positive-displacement pump

By means of an independently controlled air motor which is alternately applying pressure onto the motor piston, the recuperator piston of the pump is moved upwards and downwards.

Air motor and recuperator piston are interconnected via an coupling system.

Whilst moving upwards the suction valve is opened and the agent is sucked into the lower chamber of the hydraulic unit. Simultaneously the pressure valve located in the piston is being closed and the recuperator piston feeds the agent into the hydraulic unit.

The set spray pressure and the adopted nozzle size determine the stroke frequency, the air consumption. and thus the respective spray performance of the positive-displacement pump.

All agent conveying pump components consist of special steel 18/8

## 2 Mounting and installation

The Airless pump is to be installed in such a way as to render it easily accessible for maintenance and cleaning purposes.

The pump holder is provided with an earthing srew to which the ground wire must be connected in order to ground the static charge generated by the agent flowing within the hose.

Connect the Airless pump only with a heavy duty compressed-air supply net: designed for a maximum compressed air consumption.

**PRIOR TO START-UP, CLOSE THE PRESSURE REGULATOR OF THE AIRLESS PUMP BY COUNTER-CLOCKWISE TURNING THE HAND-WHEEL.**

The piping supplying compressed air to the Airless-pump should have a nominal width of 9.

	<b>Dokumentation</b> DOK-268-GB.doc Rev.0	Bezeichnung	HD-Pumpe
		Typ	4-50
		Artikel	7200-000

Furthermore we recommend to provide the compressed air supply net with an oil- and water separator in order to prevent foreign bodies from penetrating into both air motor and independently operating control system.

If need be a compressed air-oiler with deicing agent maybe installed between airless pump and oil/water separator.

Use only the original suction gear in order to ensure proper pump sucking.

Engage spray gun`s safety catch and connect the material supply hose at the outlet of the high-pressure filter.

WHEN IT COMES TO MATERIAL SUPPLY HOSES WITH SAFETY CONDUCTOR IN ORDER TO PREVENT ELECTROSTATIC CHARGES FROM BEING GENERATED.

CAUTION:

With regard to operating the Airless pump we prefer to the safety rules edited and published by the applicable employers liability insurance.

### 3 Start-up

- Entirely close pressure regulator at motor
- connect compressed air-hose (max. 8bar)
- in case the pump is provided with a material filter, (strongly recommended by us) a filter mesh matching the nozzle requirements must be used. See table
- Fill rinsing agent into the rinsing chamber, until the sight glass shows a 70% fillin level
- Slowly open pressure regulator until air motor starts working.
- Rinse the Airless pump by means of the rinsing agent in order to get the preservatives out of the pump
- put the suction hose into the spray agent
- open spray gun in order to evacuate the air still contained in the system
- When the spray agent starts to emerging from the spray gun, close spray gun and set the required working pressure at the pressure regulator (max 8bar)

CAUTION!

PAY ATTENTION TO THE PRESSURE TRANSFORMATION RATIO!

Under no-load conditions the Airless-pump must only be operated for a short time and at a slow running level.

Otherwise motor, suction valve, piston valve and the pump sealing may be damaged.

CAUTION!

The spay jet emerging from the spray gun is dangerous. For this reason aim the spray gun only downwards.

### 4 Switching off

Switching-off

- Entirely close pressure regulator at motor
- disconnect spray gun and render the system pressureless.
- remove and clean the spray nozzle
- remove suction hose out of the spray agent and put it in a thinner
- slowly open pressure regulator whilst the spay gun is being opened, until the air motor starts working
- rinse spray gun and pump by means of a thinner. In the process make sure that the motor runs at a slow level only
- for rough cleaning of the filter during rinsing , shortly open the cock at filter

	<b>Dokumentation</b> DOK-268-GB.doc Rev.0	Bezeichnung	HD-Pumpe
		Typ	4-50
		Artikel	7200-000

#### Maintenance

Daily check rinsing agent level during operation. Sight glass must show a 70% filling level.

In case the rinsing agent is contaminated by the spray agent, replace the rinsing agent. If, after a short time only, the rinsing agent should again be contaminated or should the rinsing agent level displayed by the sight glass increase, we recommend to replace the gasket set, item 22 and item 30.

By replacing these gasket sets, the recuperator piston prevented from being worn out prematurely.

We recommend to open the material filter at fixed intervals in order to clean the filter housing, mesh inclusive.

#### CAUTION!

Prior to opening material filter refer to instructions

## 5 Technical data

Air consumption

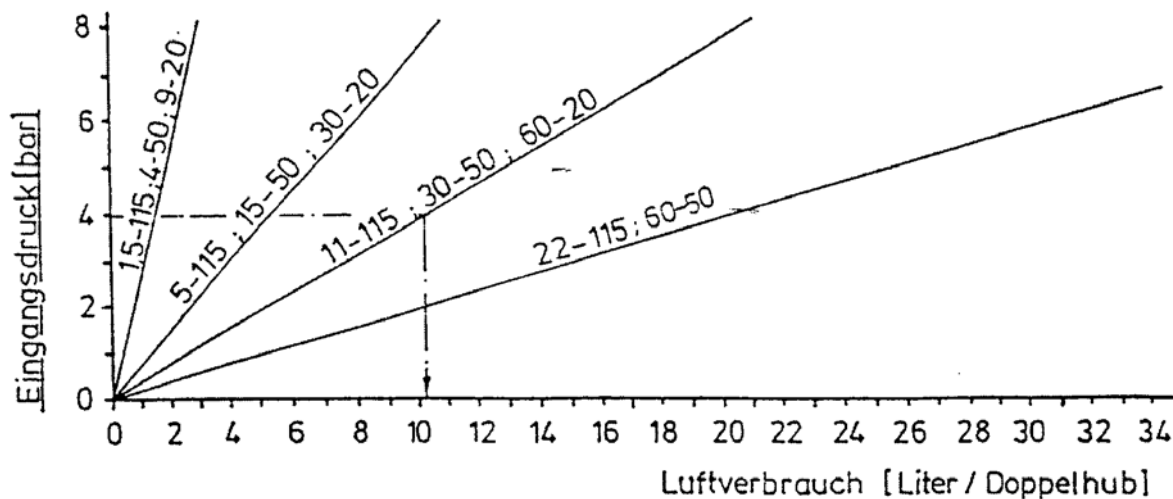

Example  
input air pressure: 4,0bar  
pump type: 4-50  
air consumption/double stroke: 5.45litres

pressure transformation ratio	4:1
delivery volume/double stroke	100ccm
max. recommended double strokes/minute	50
max. air pressure	8bar
max. spray agent pressure in bar	32bar
recommended delivery volume	5,0l/min (50 double strokes/minute)
max. delivery volume	10,0l/min (100 double strokes/minute)

	<b>Dokumentation</b> DOK-268-GB.doc Rev.0	Bezeichnung	HD-Pumpe
		Typ	4-50
		Artikel	7200-000

## 6 Trouble shooting guide

kind of malfunction origin of malfunction (unit)	pump does not start or Stopps running durin operation	no or insufficient pump sucking	spray pressure to low	uneven operation of pump	pump continues running even though spray gun is closed	pump feeds agent into rinsing chamber	iced control
drive	clean control and defective parts			clean control and defective parts			pump runs too fast
hydraulic unit		insufficient venting, leaking screwing between hydraulic unit and suction gear		insufficient venting, leaking screwing between hydraulic unit and suction gear			
suction gear		mesh basket obstructed		mesh basket obstructed			
high pressure filter	filter contaminated, check for passage and cleanliness						
high pressure material hose	choked hose, check for passage and cleanliness						
suction/pressure valve		worn or blocked, replace defective parts					
sealing sets		leaking gaskets				upper gasket set leaking	
atomizer nozzle	nozzle bore choked		excessive nozzle bore				excessive nozzle bore
pressure reducing valve	air pressure too low		air pressure too low				
compressed air piping	insufficient air quantity, air pressure too low		insufficient air quantity, air pressure too low				
spray agent		viscosity too high					

## 7 Units of the airless-pump 4-50

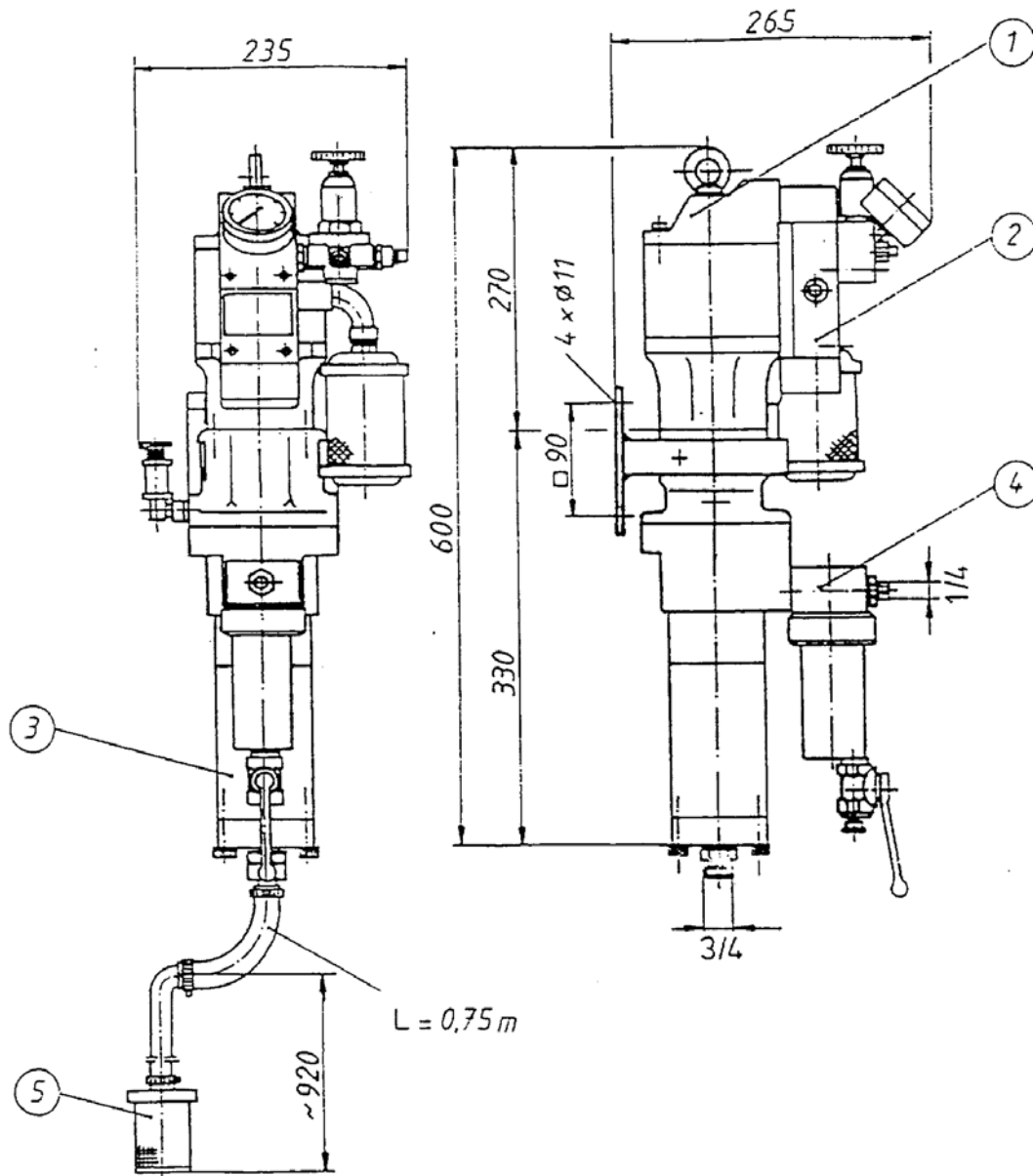

Item	designation	Order No.
1	motor, compl.	080-0414
2	control unit, compl.	080-3141
3	Hydraulic section, compl.	090-0008
4	filter compl.	080-0013
5	suction gear, compl.	080-0298

	<b>Dokumentation</b> DOK-268-GB.doc Rev.0	Bezeichnung	HD-Pumpe
		Typ	4-50
		Artikel	7200-000

### 1.1. spare parts list motor 70

Item	Order No.	designation
1	7200-040-0425	Lower part
2	7200-040-0426	Upper part
3	7200-040-0427	Cylinder tube
4	7200-040-0428	Piston
5	7200-040-0429	Piston rod
6	7200-040-0034	Tappet rod (2 pcs)
9	7200-080-3141	Control unit complete, <b>8bar</b> pressure
9	7200-080-3142	Control unit complete, <b>6bar</b> pressure
10	7200-040-1301	Bushing
11	7200-020-0076	Pressure spring (2 pcs)
12	7200-030-0143	Ring bolt
13	7200-040-4896	screw (2 pcs)
14	7200-030-0533	Screw (2 pcs)
15	7200-030-0509	Srew (4 pcs)
16	7200-030-0510	Screw
17	7200-030-0706	Safety disk (8 Stück)
18	7200-030-2804	Safety ring
19	7200-030-0719	Safety disk (2 Stück)
20	7200-030-2857	Disk (2 Stück)
21	7200-030-2856	Disk (2 Stück)
22	7200-030-2867	Disk
23	7200-040-0436	Disk
* 24	7200-010-0247	gasket (2 pcs)
* 25	7200-010-0241	O-Ring (2 pcs)
* 26	7200-010-0249	O-Ring
* 27	7200-010-0250	O-Ring (2 pcs)
* 28	7200-010-0190	Gasket
* 29	7200-010-0253	Gasket
30	7200-040-0062	coupling (2 pcs)
31	7200-020-0150	Spring clip

\* gasket set



Spare parts drawing motor

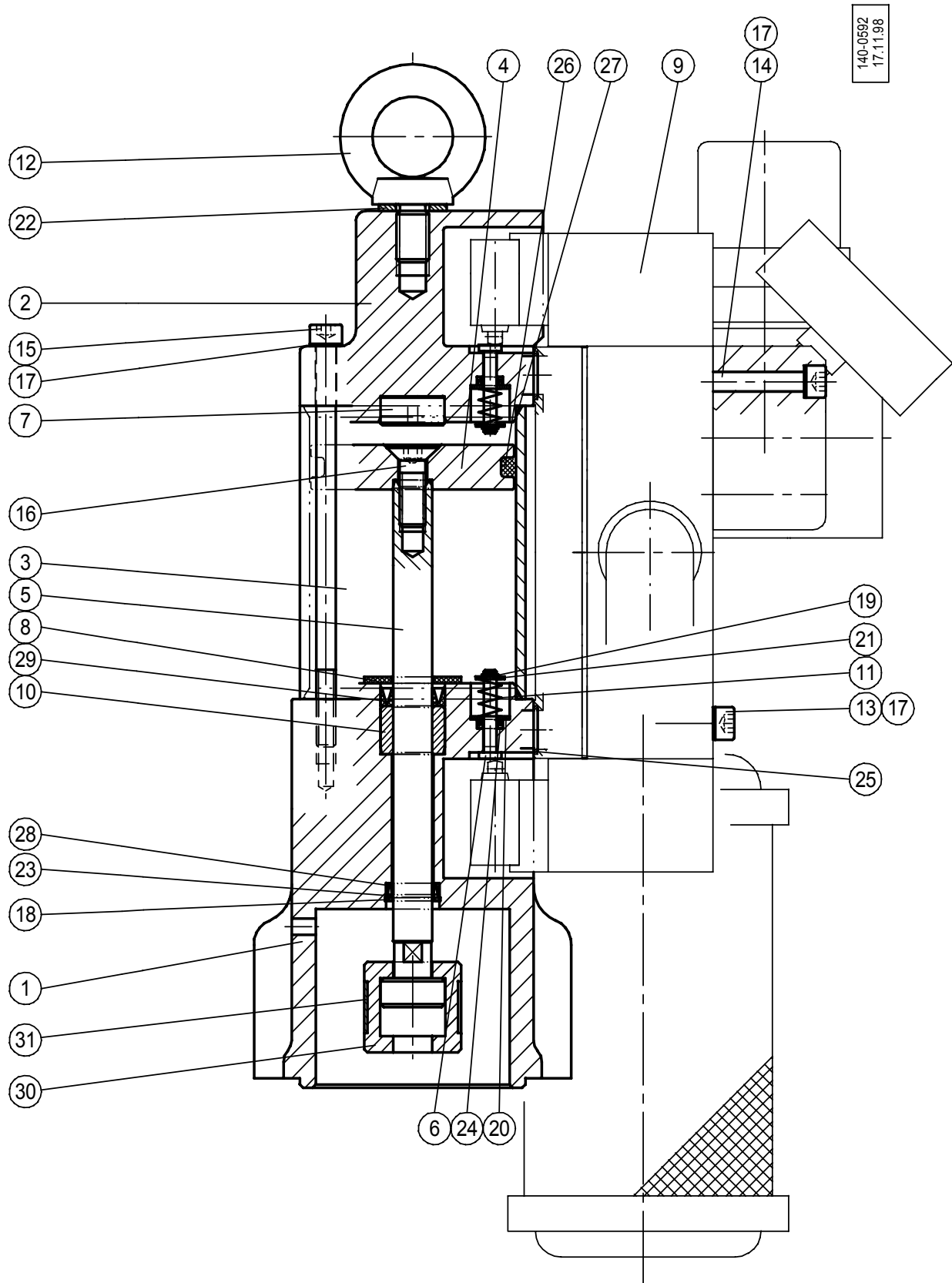

	<b>Dokumentation</b> DOK-268-GB.doc Rev.0	Bezeichnung	HD-Pumpe
		Typ	4-50
		Artikel	7200-000

**spare parts list control unit, 8bar pressure**

Pos.	Bestell-Nr.	Bezeichnung
1	7100-080-0197	Air distributor.
2	7100-130-0305	Control valve. (incl. Item. 21-25)
3	7100-040-0446	Connector
4	7100-030-0294	Screw (2 pcs)
5	7100-030-0706	Safety disk (2 pcs)
6	7100-030-0720	Manometer
* 7	7100-010-0251	Gasket
* 8	7100-010-0243	O-Ring
* 9	7100-010-0244	Gasket
* 10	7100-010-0245	Gasket
* 11	7100-010-0287	gasket (2 pcs)
12	7100-030-0708	Extension
13	7100-030-2020	Bend
14	7100-030-1991	Double nipple (2 pcs)
15	7100-030-0711	Silecer
16	7100-030-1313	Pressure reducer
17	7100-130-0179	Safety valve, 8 bar
18	7100-080-0207	Angle fitting
19	7100-030-2406	Fitting
20	7100-100-0439	pipe,length 82 mm
21	7100-080-3017	<sup>5</sup> / <sub>2</sub> -way valve, cpl.
22	7100-130-0306	<sup>3</sup> / <sub>2</sub> -way valve, cpl. (2 pcs)
23	7100-030-0294	screw (8 pcs)
24	7100-030-0706	Safety disk (8 pcs)
* 25	7100-010-0636	O-Ring (6 pcs)

\* gasket set

Spare parts drawing control unit

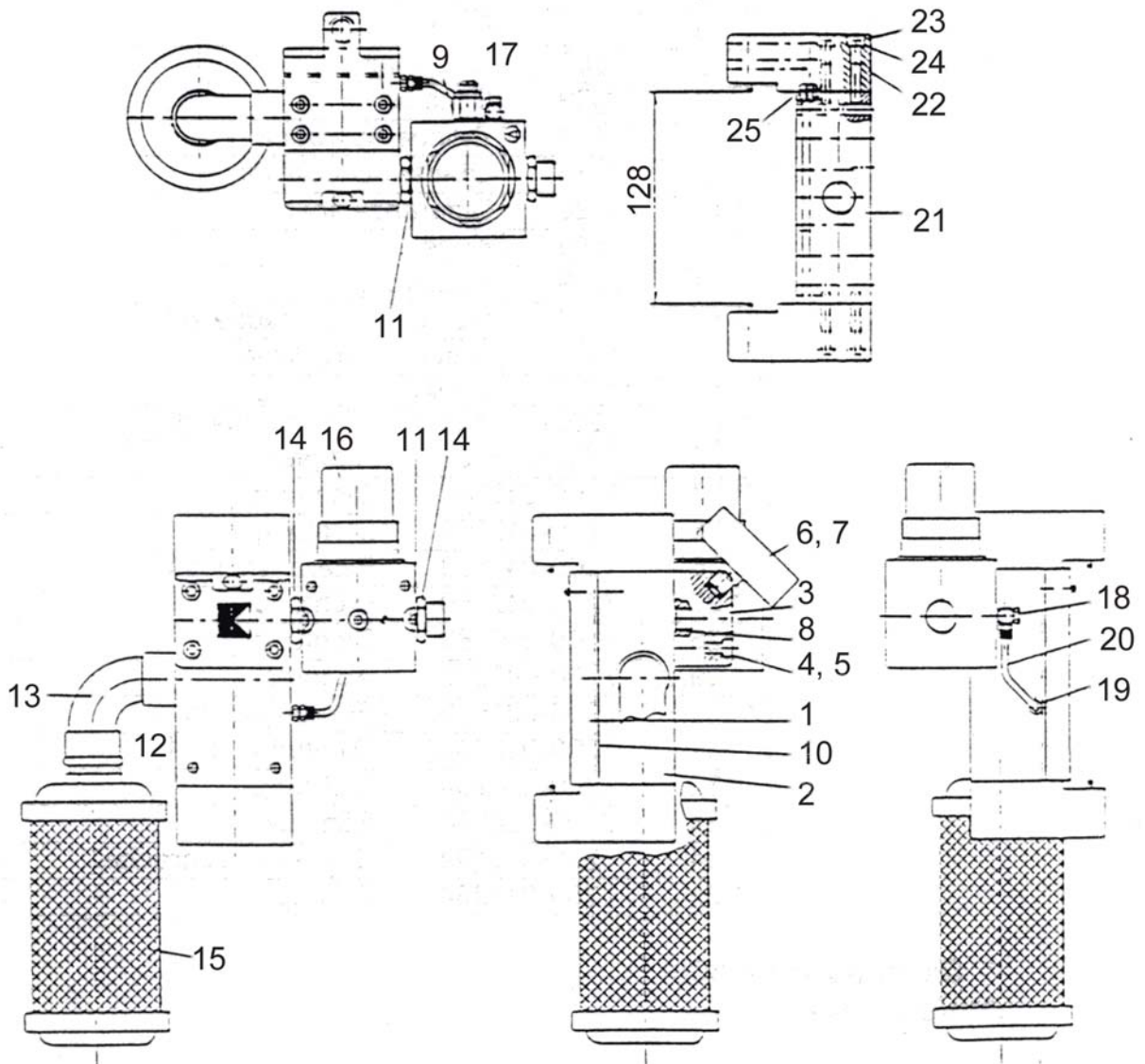

	<b>Dokumentation</b> DOK-268-GB.doc Rev.0	Bezeichnung	HD-Pumpe
		Typ	4-50
		Artikel	7200-000

## 1.2. spare parts list hydraulic system; (with built-on filter)

Pos.	Bestell-Nr.	Bezeichnung
1.	7100-080-0006	Pump holder
2.	7100-030-0524	Screw
3.	7100-030-0714	Safety disk
4.	7100-030-0516	Thread plug
5.	7100-040-0461	Ring
6.	7100-040-0457	Filter panel
7.	7100-030-2869	Disk
8.	7100-030-0514	Screw
9.	7100-040-0618	Upper part tube
** 10.	7100-040-0620	Piston
** 11.	7100-030-2749	Ball
12.	7100-040-0599	Ball valve seat
** 13.	7100-080-0009	Fastener screw
14.	7100-040-0619	Lower part tube
** 15.	7100-030-0701	Ball
** 16.	7100-080-0007	Pump fastener
* 17.	7100-010-0288	Gasket
18.	7100-040-0025	Screw in socket
19.	7100-040-0455	Rinsing chamber
20.	7100-030-1879	Gauge
* 21.	7100-010-0244	Gasket
** 22.	7100-030-1885	Gasket
23.	7100-040-0622	Adapter
** 24.	7100-010-0280	Gasket
* 25.	7100-010-0265	Gasket
26.	7100-040-0603	Filter connection
* 27.	7100-010-0260	Gasket
** 28.	7100-010-0282	Gasket
29.	7100-040-0623	Adapter
** 30.	7100-030-1886	Gasket
* 31.	7100-010-0268	Gasket
* 32.	7100-010-0264	Gasket
33.	7100-030-2874	Disk
34.	7100-030-0499	Screw
* 35.	7100-010-0284	O-Ring

\* gasket set 010-0868

\*\* wearing parts

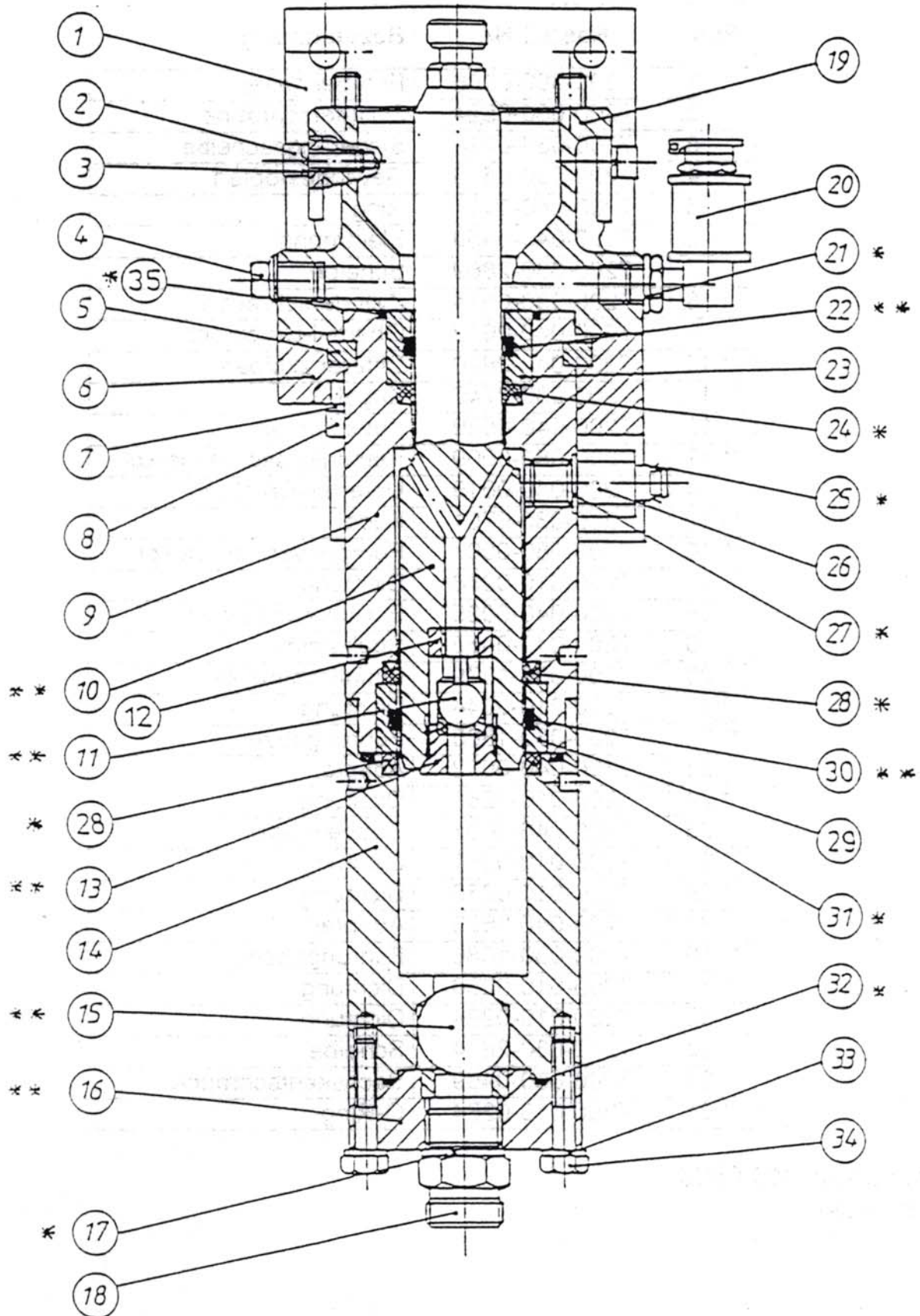

<b>Krautzberger</b> 	<b>Dokumentation</b> DOK-268-GB.doc Rev.0	Bezeichnung	HD-Pumpe
		Typ	4-50
		Artikel	7200-000

### 1.3. spare parts list hydraulic system

Pos.	Bestell-Nr.	Bezeichnung
1.	7100-080-0006	Pump holder
2.	7100-030-0524	Screw
3.	7100-030-0714	Safety disk
4.	7100-030-0516	Thread plug
5.	7100-040-0461	Ring
6.	7100-040-0459	Ring clip
7.	7100-030-2869	Disk
8.	7100-030-0514	Srew
9.	7100-040-0618	Upper part tube
** 10.	7100-040-0620	Piston
** 11.	7100-030-2749	Ball
12.	7100-040-0599	Ball valve seat
** 13.	7100-080-0009	Fastener screw
14.	7100-040-0619	Lower part tube
** 15.	7100-030-0701	Ball
** 16.	7100-080-0007	Pump fastener
* 17.	7100-010-0288	Gasket
18.	7100-040-0025	Screw in socket
19.	7100-040-0455	Rinsing chamber
20.	7100-030-1879	Gauge
* 21.	7100-010-0244	Gasket
** 22.	7100-030-1885	Gasket
23.	7100-040-0622	Adapter
** 24.	7100-010-0280	Gasket
26.	7100-040-0601	Double nipple
* 27.	7100-010-0260	Gasket
** 28.	7100-010-0282	Gasket
29.	7100-040-0623	Adapter
** 30.	7100-030-1886	Gasket
* 31.	7100-010-0268	Gasket
* 32.	7100-010-0264	Gasket
33.	7100-030-2874	Disk
34.	7100-030-0499	Srew
* 35.	7100-010-0284	O-Ring

\* gasket set 010-0868

\*\* wearing parts

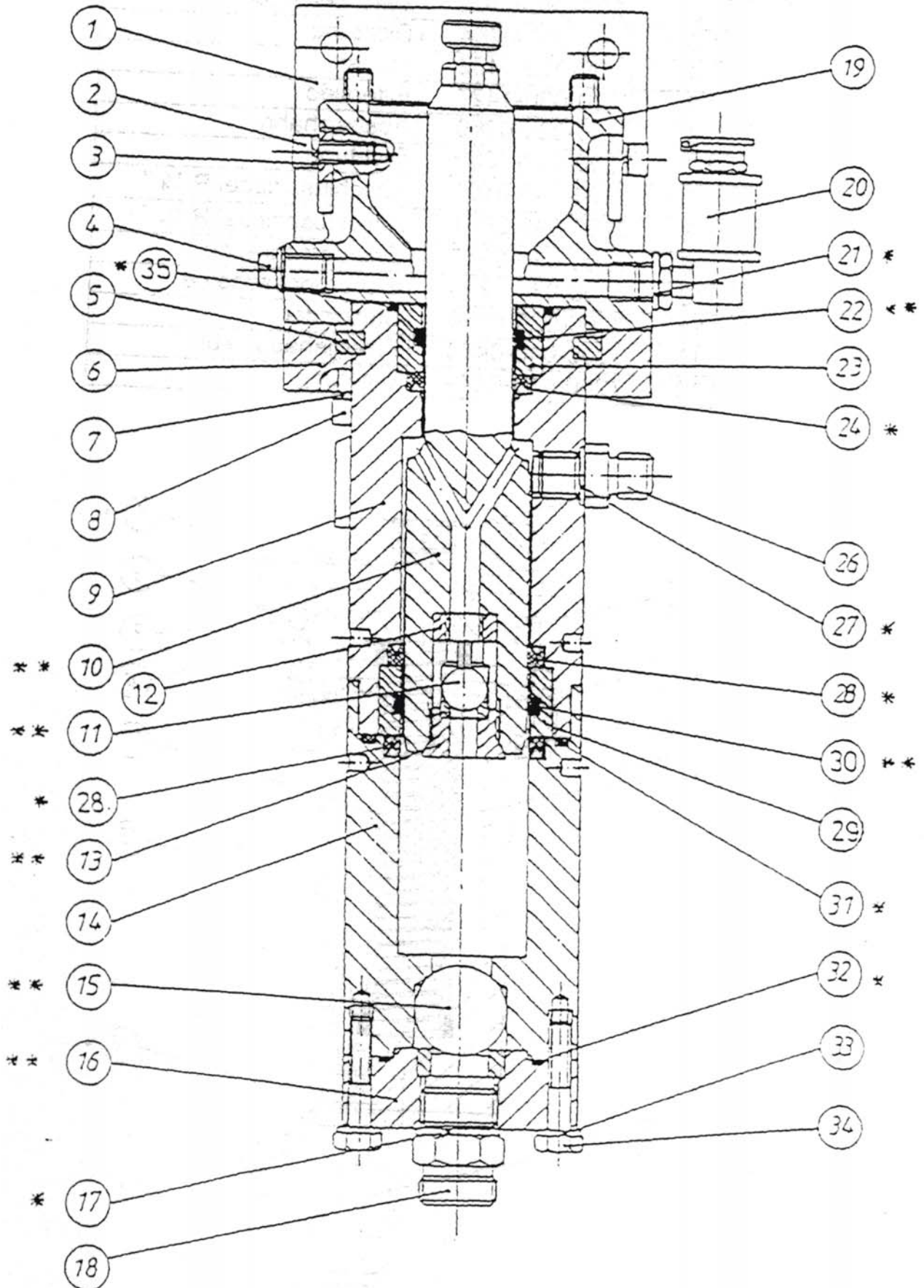

	<b>Dokumentation</b> DOK-268-GB.doc Rev.0	Bezeichnung	HD-Pumpe
		Typ	4-50
		Artikel	7200-000

spare parts list filter

Pos.	Bestell-Nr.	Bezeichnung
1.	7100-030-0526	Screw
2.	7100-040-0462	<a href="#">intermediate piece</a>
* 3.	7100-010-0264	Gasket
4.	7100-030-1452	Nut
** 5.	7100-030-1427	Mesh
6.	7100-030-0960	Stopp-cock
* 7.	7100-010-0260	Gasket
8.	7100-040-0601	Connection R 1/4 "
8.	7100-040-0061	Connection R 3/8 "
9.	7100-030-0515	Srew
10.	7100-030-0714	Safety disk
11.	7100-020-0056	Spring
12.	7100-040-0463	Housing, compl.
* 13.	7100-010-0244	gasket

\* gasket set

\*\* wearing parts



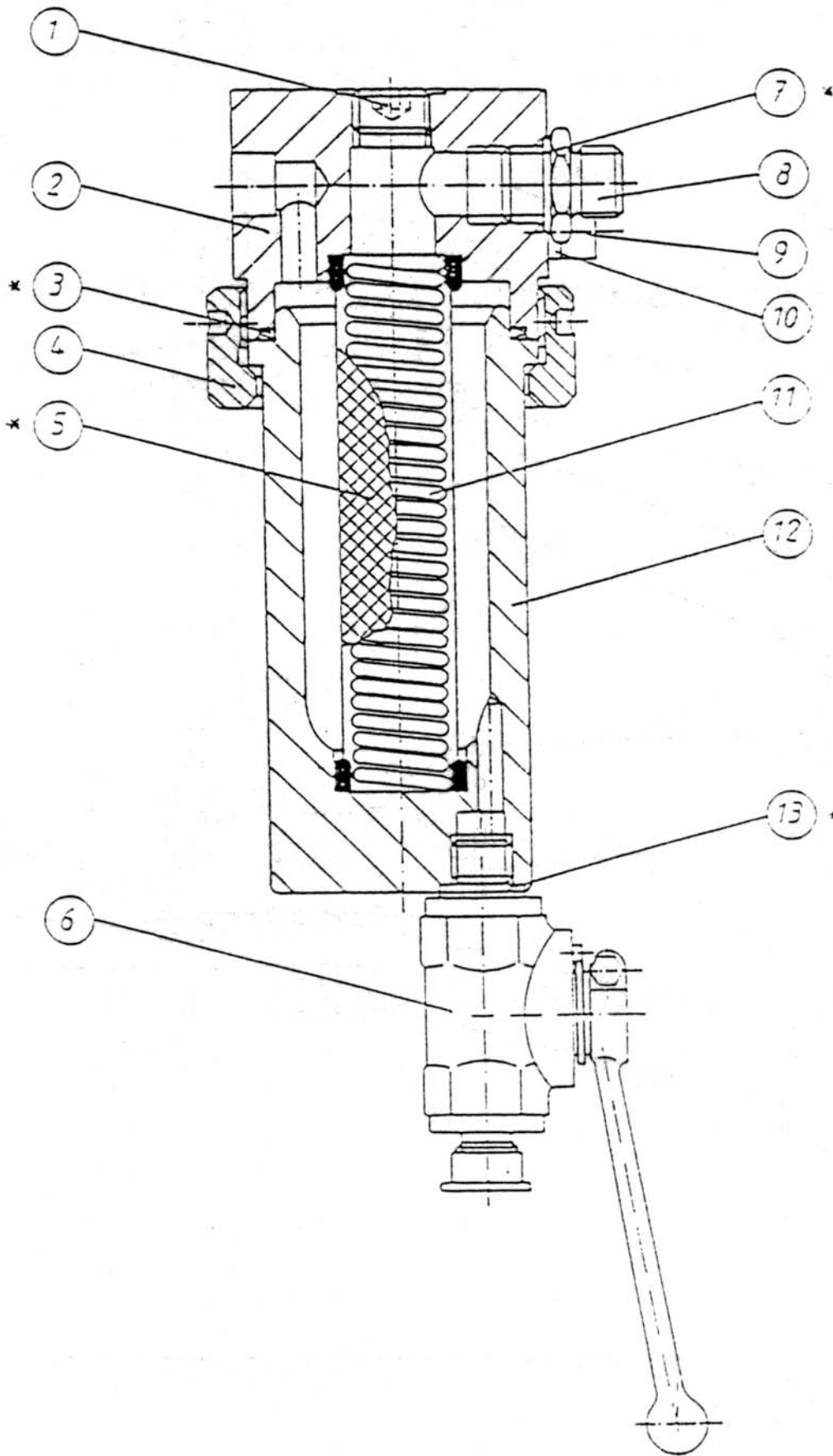

<b>Krautzberger</b> 	<b>Dokumentation</b> DOK-268-GB.doc Rev.0	Bezeichnung	HD-Pumpe
		Typ	4-50
		Artikel	7200-000

## 8 Declaration of conformity

### EG-Konformitätserklärung

im Sinne der EG-Maschinenrichtlinie 89/392/EWG, Anhang II A

Hiermit erklären wir.

**Krautzberger GmbH, Spritztechnik**  
**Stockbornstraße 13, Postfach 13 51**  
**65343 Eltville am Rhein (65333 Postfach)**

daß die nachfolgend bezeichnete Maschine aufgrund ihrer Konzipierung und Bauart sowie in der von uns in Verkehr gebrachten Ausführung den einschlägigen grundlegenden Sicherheits- und Gesundheitsanforderungen der EG-Richtlinien entspricht.  
Bei einer nicht mit uns abgestimmten Änderung der Maschine verliert diese Erklärung ihre Gültigkeit.

Bezeichnung der Maschine: *Kolbenpumpe*

Maschinentyp: *Typ 4 - 50*

Maschinen-Nr.: *7200 - 000*

Einschlägige EG-Richtlinien: EG-Maschinenrichtlinie (89/392/EWG) i.d.F. 93/44/EWG

Angewandte harmonisierte Normen , insbesondere: DIN 24374 / 1

Angewandte nationale Normen und technische Spezifikationen insbesondere: DIN 24295

Datum/Herstellerunterschrift: *28.12.94*



Angaben zum Unterzeichner: technischer Leiter

<b>Krautzberger</b> 	<b>Dokumentation</b> DOK-268-GB.doc Rev.0	Bezeichnung	HD-Pumpe
		Typ	4-50
		Artikel	7200-000